

Visualization and Biology: Fertile Ground for Collaboration

Tamara Munzner

Department of Computer Science

University of British Columbia

February 2009

<http://www.cs.ubc.ca/~tmm/talks.html#harvard09>

Outline

- visualization ideas and background
- combining interaction networks, microarray data
 - Cerebral system
- comparing phylogenetic trees
 - TreeJuxtaposer system
- discussion

Why do visualization?

- pictures help us think
 - substitute perception for cognition
 - external memory: free up limited cognitive/memory resources for higher-level problems

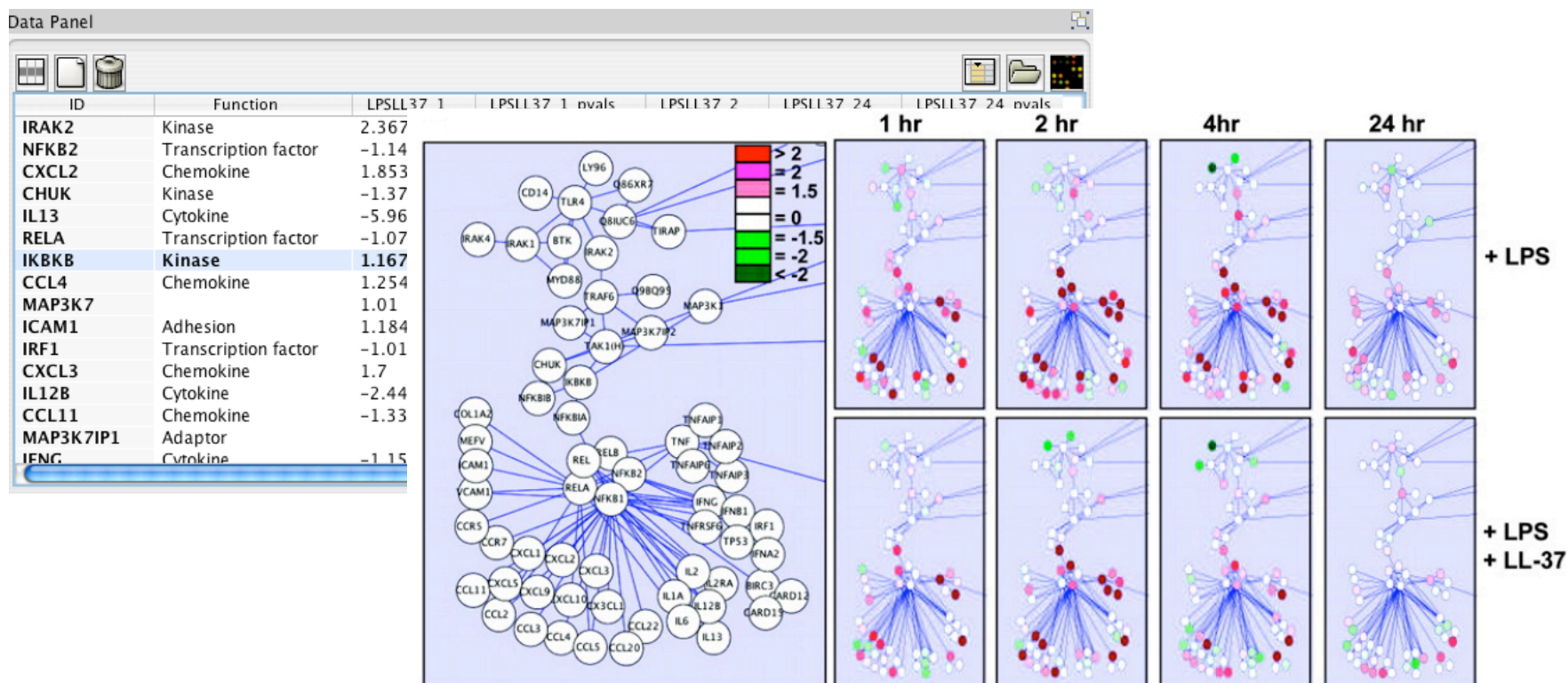

When should we bother doing vis?

- need a human in the loop
 - augment, not replace, human cognition
 - for problems that cannot be (completely) automated
- simple summary not adequate
 - statistics may not adequately characterize complexity of dataset distribution

Anscombe's quartet:
same

- mean
- variance
- correlation coefficient
- linear regression line

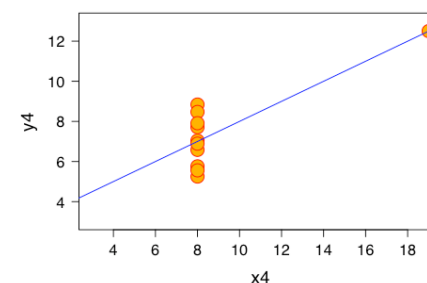
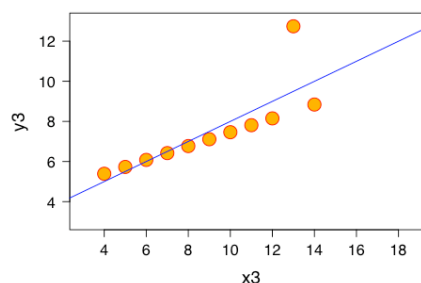
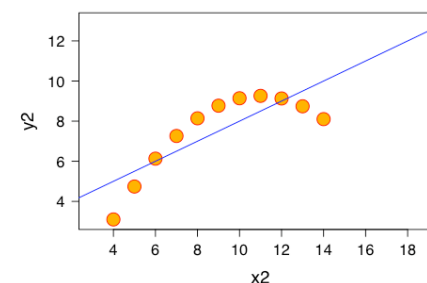
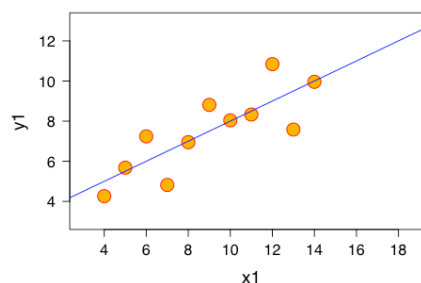

<http://upload.wikimedia.org/wikipedia/commons/b/b6/Anscombe.svg>

What does visualization allow?

- discovering new things
 - hypothesis discovery, “eureka moment”
- confirming conjectured things
 - hypothesis confirmation
- contradicting conjectured things
 - especially (inevitably?) data cleansing
- novel capabilities
 - tool supports fundamentally new operations
- **speedup**
 - tool accelerates workflow (most common!)

Multiple levels of problem-driven vis

- cascading levels: output above is input below

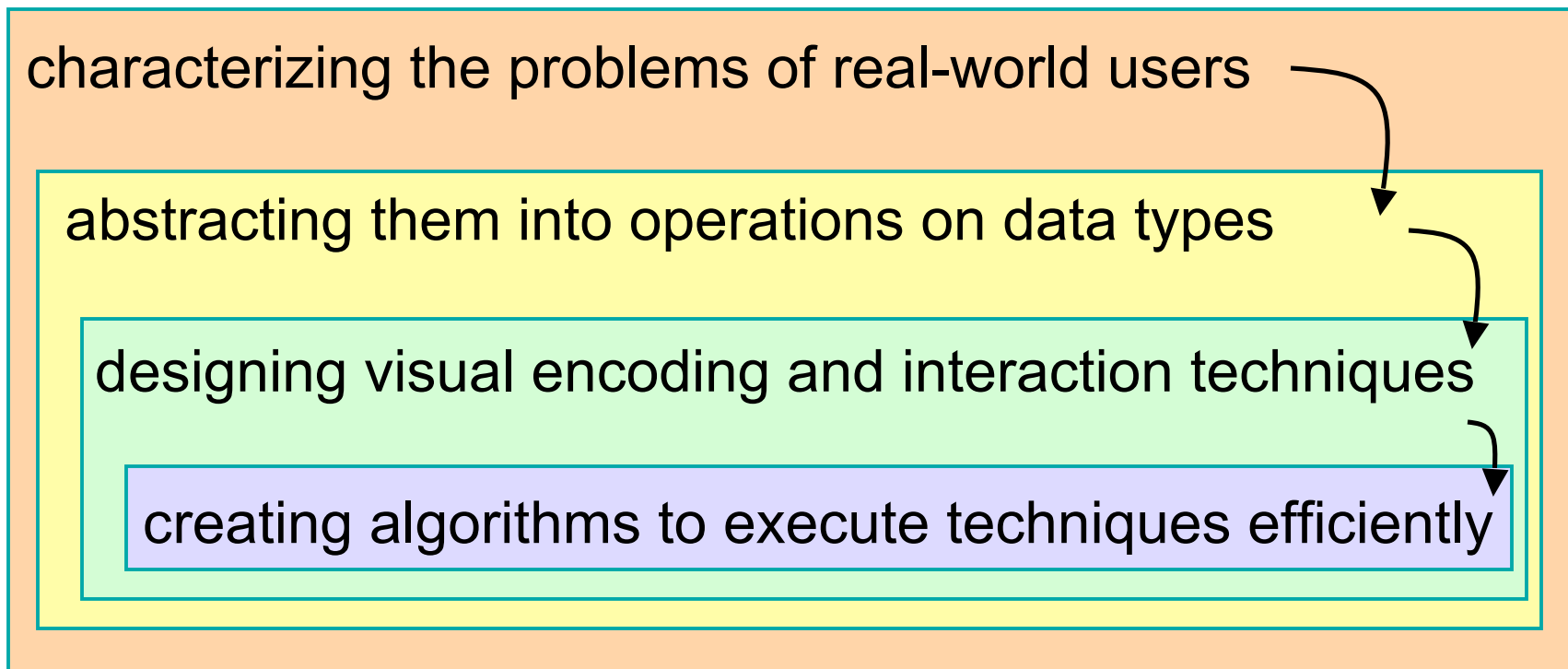

Characterizing problems

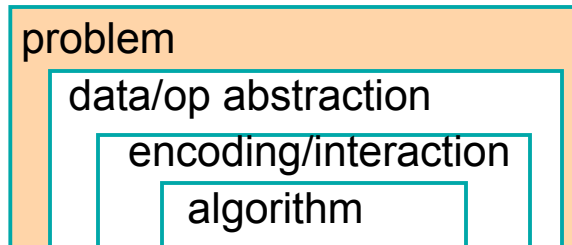

- understanding domain concepts and current workflow
- finding gaps, breakdowns, slowdowns
 - where conjecture that vis would help

Abstracting into operations on data types

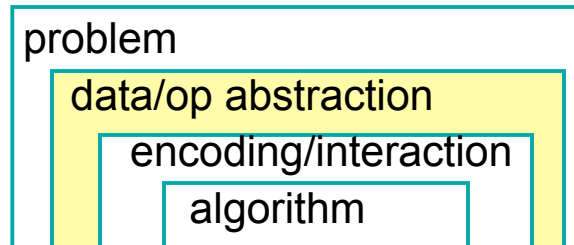

- **data types**
 - tables of numbers
 - relations: networks/graphs, hierarchies/trees
 - spatial data: geographic, positions in space
- **operations**
 - sorting, filtering, browsing, comparison, characterizing trends and distributions, finding anomalies and outliers, finding correlation...
 - relations: following path through network...

Designing encoding and interaction

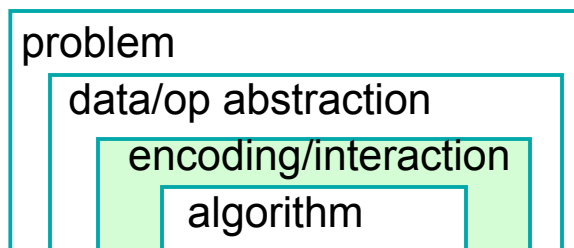

- visual encoding
 - marks: points, lines, areas
 - attributes: position, color, shape, size, orientation, ...
- interaction
 - selecting, navigating, ordering, ...

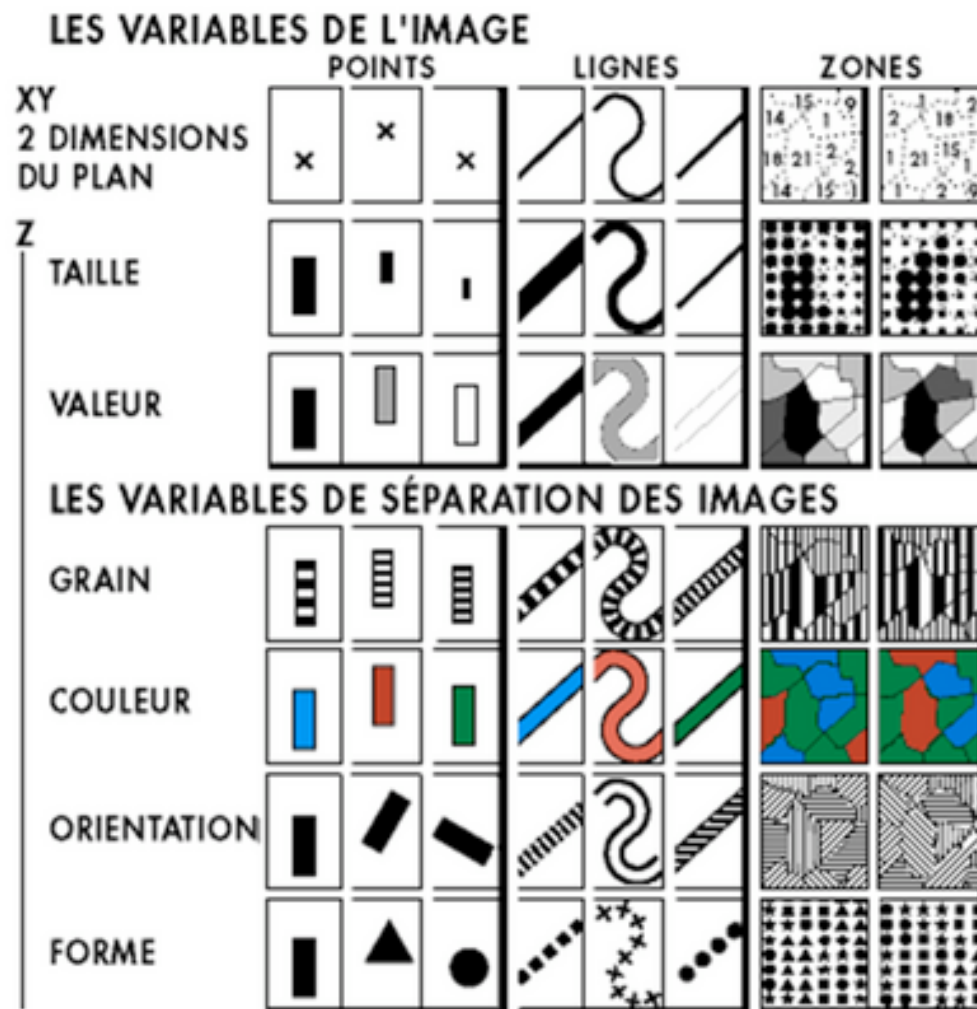

Creating efficient algorithms

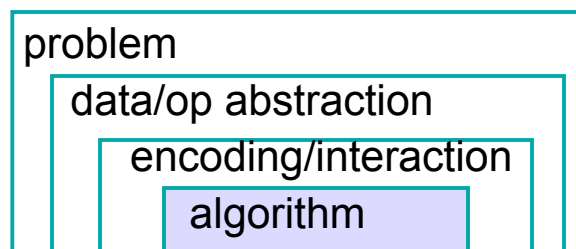

- classic computer science problem
 - create algorithm given clear specification

Design decisions

- huge space of design alternatives
 - conflicting tradeoffs
 - iterative refinement often necessary
- many/most choices are ineffective
 - wrong visual encoding can mislead, confuse
 - principled reasons to make choices usually not obvious to untrained people

Validation: Is problem solved?

- humans in the loop for outer three levels

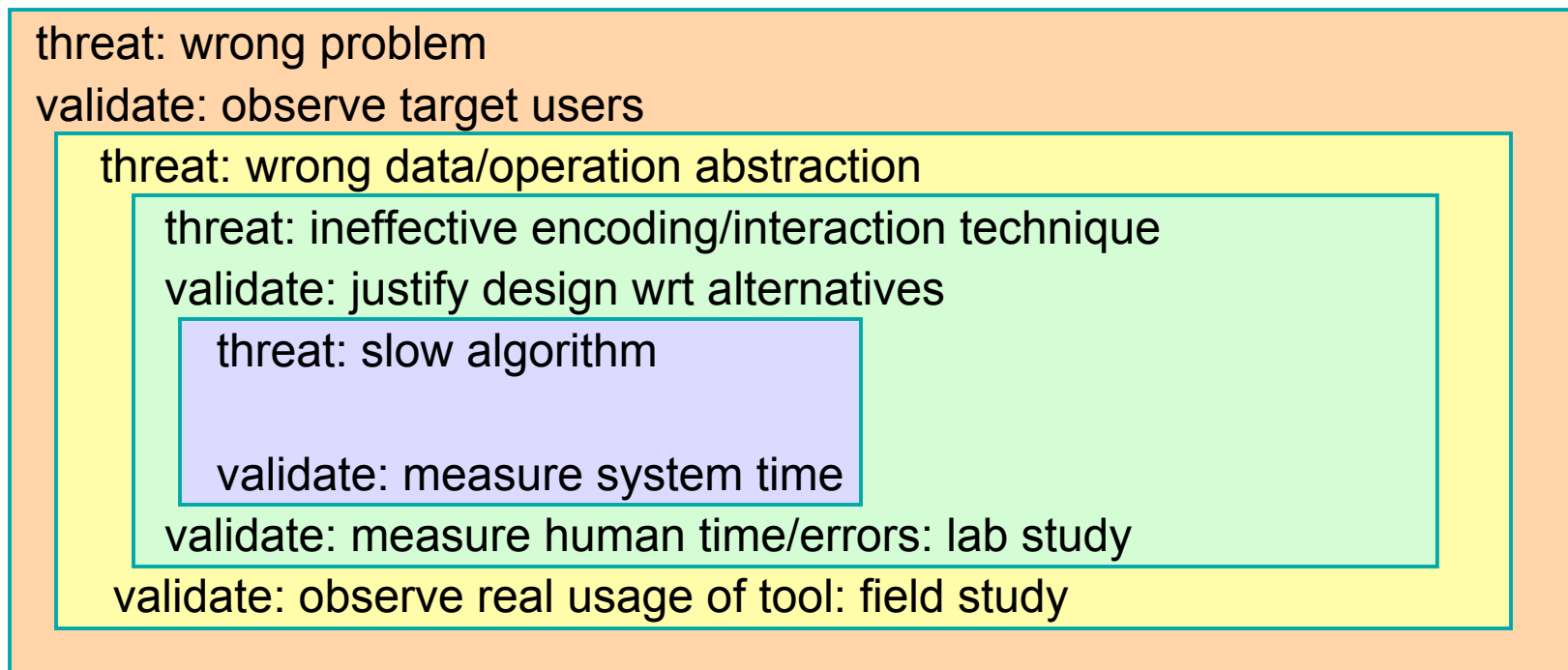

Collaboration: Complementary expertise

- vis researchers
 - vis design alternatives
 - human perceptual capabilities
 - scalable graphics algorithms
 - validation methodology
- domain scientists
 - deep knowledge of driving problems, data
- both benefit from new tools
 - scientist: you get something helpful
 - vis researcher: we get to watch you use it
 - see if problem actually solved
 - feed new knowledge back into our design principles

Good driving problems for vis research

- big data
- reasonably clear questions
- need for humans in the loop

- many areas of science are a great match
 - biology particularly appealing

Outline

- visualization ideas and background
- combining interaction networks, microarray data
 - Cerebral system
- comparing phylogenetic trees
 - TreeJuxtaposer system
- discussion

Cerebral

collaboration with researchers at UBC Hancock Lab studying innate immunity

Cerebral: Visualizing Multiple Experimental Conditions on a Graph with Biological Context

Aaron Barsky, Computer Science, UBC

Tamara Munzner, Computer Science, UBC

Jennifer Gardy, Microbiology and Immunology, UBC

Robert Kincaid, Agilent Technologies

IEEE Transactions on Visualization and Computer Graphics (Proc. InfoVis 2008) 14(6) (Nov-Dec) 2008, p 1253-1260.

<http://www.cs.ubc.ca/labs/imager/tr/2008/cerebral/>

<http://www.cs.ubc.ca/labs/imager/th/2008/BarskyMscThesis/>

open-source software download (Cytoscape plugin)

<http://www.pathogenomics.ca/cerebral/>

deployed in InnateDB (mammalian innate immunity database)

<http://www.innatedb.ca>

Systems biology model

- graph $G = \{V, E\}$
 - V: proteins, genes, DNA, RNA, tRNA, etc.
 - E: interacting molecules

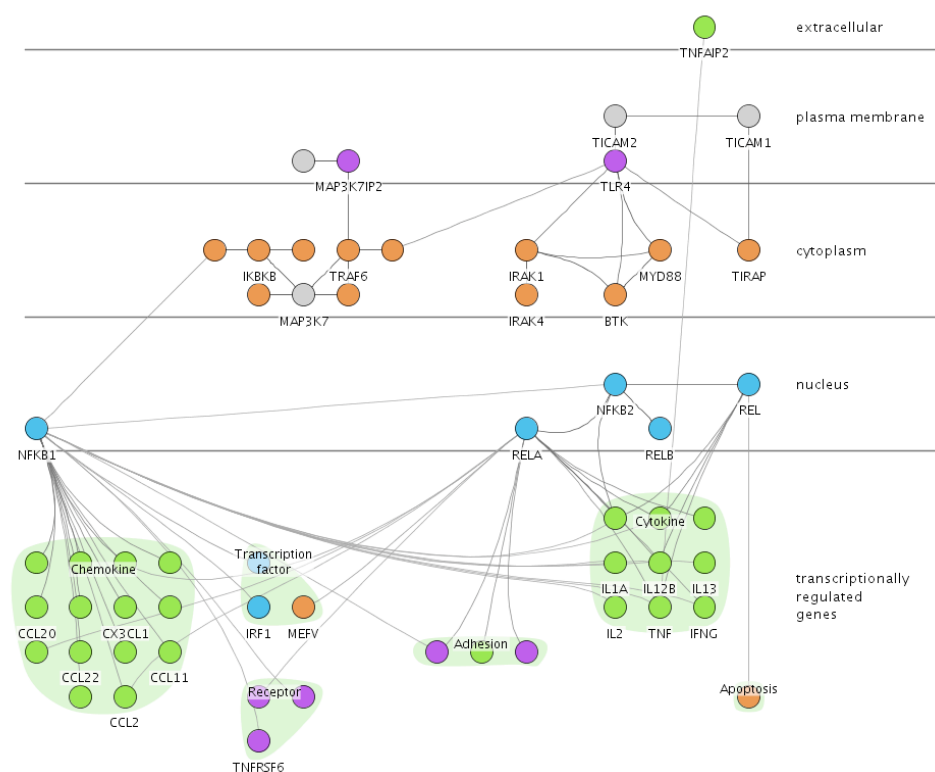

Model - Experiment cycle

- conduct experiments on cells
- interpret results in current graph model
- propose modifications to refine model

- vis tool to accelerate workflow?

Goal: Integrate model with measurements

- system model
 - interaction graph
 $G = \{V, E\}$
 - meta-data for each v in V
 - labels, biological attributes
- experimental measurements
 - multiple floats for each v in V
 - microarray data

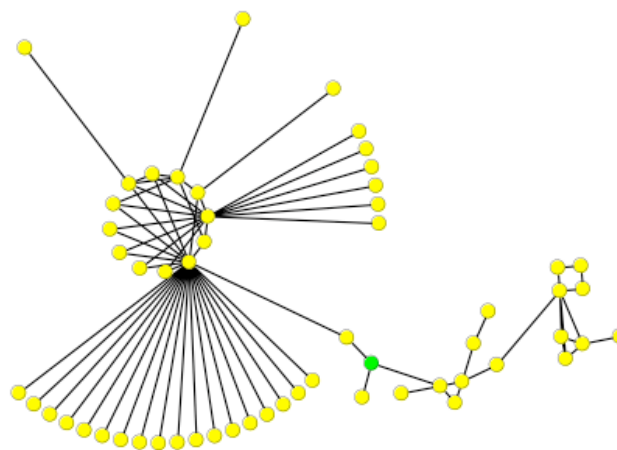

Data Panel

ID	Function	LPSLL37_1	LPSLL37_1_pvals	LPSLL37_2	LPSLL37_24	LPSLL37_24_pvals
IRAK2	Kinase	2.367	0.251	1.337	-1.553	
NFKB2	Transcription factor	-1.14	0.972	-1.03	1.303	0.807
CXCL2	Chemokine	1.853	0.376	4.111	-1.019	0.745
CHUK	Kinase	-1.376	0.373	2.232	1.194	0.387
IL13	Cytokine	-5.961		2.139	-1.236	0.601
RELA	Transcription factor	-1.077	0.564	-1.169	1.943	0.594
IKBKB	Kinase	1.167	0.29	1.421	-1.907	0.286
CCL4	Chemokine	1.254	0.878	-1.052	1.499	0.761
MAP3K7		1.01	0.956	-1.096	1.222	0.8
ICAM1	Adhesion	1.184	0.669	1.537	1.392	0.671
IRF1	Transcription factor	-1.013	0.519	1.416	1.081	0.995
CXCL3	Chemokine	1.7	0.905	1.092	-1.598	0.521
IL12B	Cytokine	-2.448	0.042	-1.473	-2.109	0.08
CCL11	Chemokine	-1.338	0.349	-1.995	-1.785	0.129
MAP3K7IP1	Adaptor					
JENG	Cytokine	-1.15	0.801	1.075	1.053	0.521

Model summarizes extensive lab work

- graphs come from hand-curated databases
 - dynamic, change with each new publication
- each edge has provenance from experimental evidence
 - TIRAP: an adapter molecule in the Toll signaling pathway. *Horng T, Barton GM, Medzhitov R.*
 - Mal (MyD88-adapter-like) is required for Toll-like receptor-4 signal transduction. *Fitzgerald KA, Palsson-McDermott EM, Bowie AG, Jefferies CA, Mansell AS, Brady G, Brint E, Dunne A, Gray P, Harte MT, McMurray D, Smith DE, Sims JE, Bird TA, O'Neill LA.*

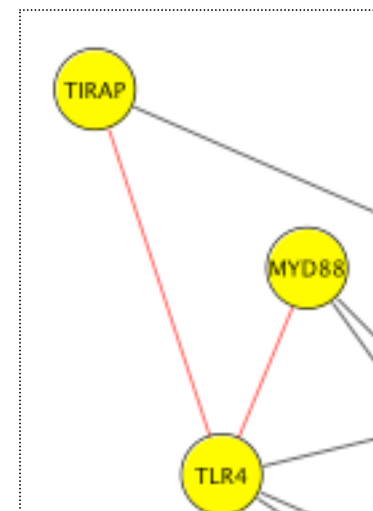

- choose scope to manage complexity

TLR4 biomolecule: E=74, V=54

- very local view

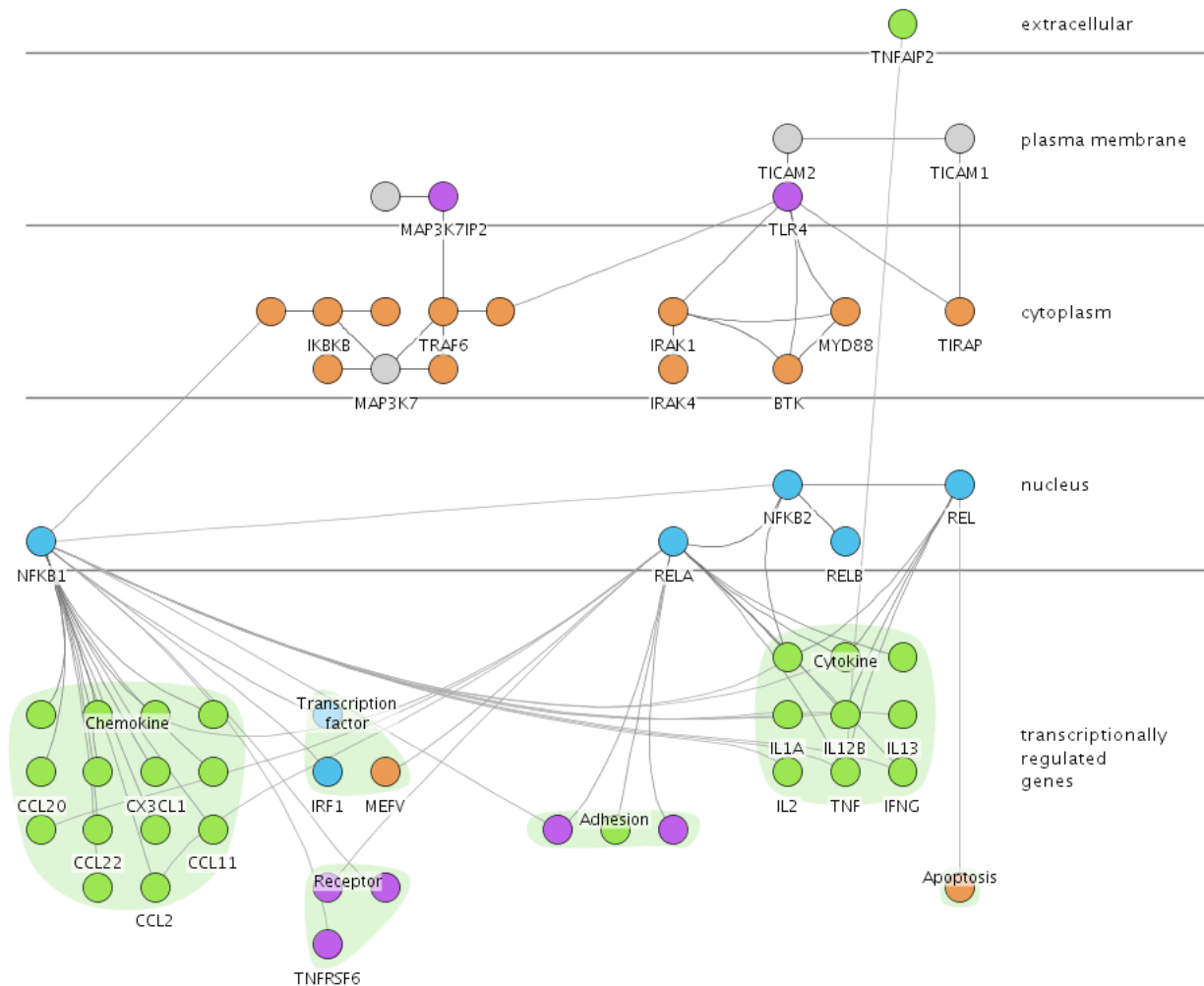

Immune system: $E=1263$, $V=760$

- bigger picture, target size for Cerebral

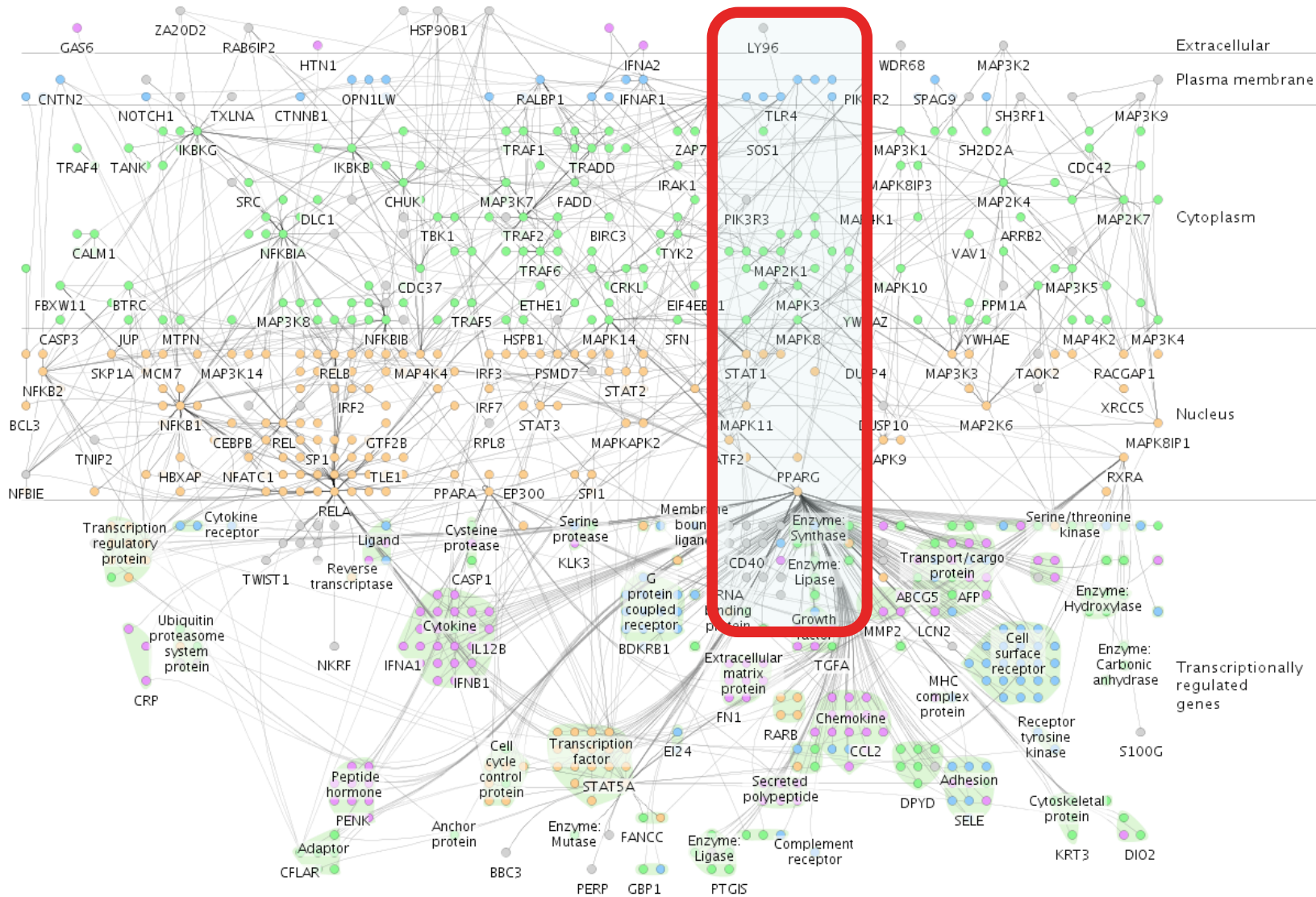

Human interactome: $E \sim 50,000$, $V \sim 10,000$

- too complex, beyond scope of tool

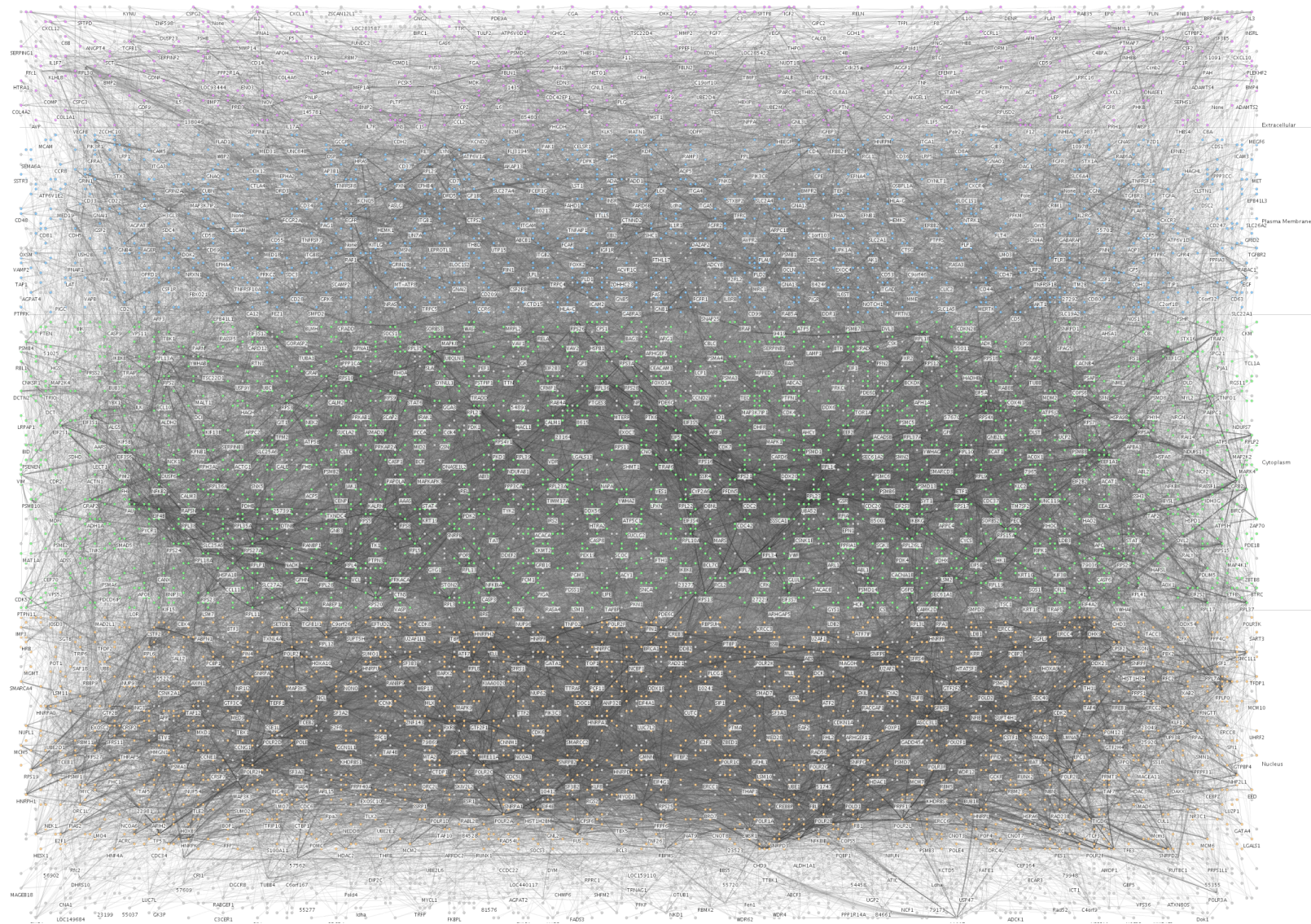

Cerebral video

File Edit View Select Layout Plugins Help

CytoPanel 1

Network Cerebral Editor

Edge curviness: Straight Bundled

Label density: Dense Sparse

Group label size: Off Small Large

Show function clusters Show layer separators High quality rendering

Relayout

Expression color scale: -5 to 5

Comparison color scale: -1.5 to 1.5

Significance cut-off: 1

Expression cutoff: 0

Expression data are ratios

Groups

tlr4_sif.sif

Change from LPS_4 to LPSLL37_4

extracellular

plasma membrane

cytoplasm

nucleus

transcriptionally regulated genes

Structural: ACTC, APOE

Cytoskeleton: IRF1

Transcription factor: IRF3, IRF7, IRF1

Receptor: TNFRSF6, CCR7

Adhesion: VCAM1, COL1A2

Chemokine: CXCL2, CCL5, CXCL3, CXCL9

Cytokine: IL12B, IL6, IL2RA, TNF, TNFAIP6

Apoptosis: BIRC3

Unknown: REL

Other nodes: LY96, TICAM2, MBP, TLR4, TICAM1, MAPK8, BTK, IRAK1, MAP3K7IP2, TRAF6, IKKBE, PRKRA, MAP2K4, MAP3K1, MYD88, MAPK13, MAPK10, MAPK8IP3, MAPK1, IKKBK, CHUK, MAP3K7IP1, MAPK9, NR2C2, NFKB2, IRF3, MAPK11, NFKB1, REL

CytoPanel 2

28 9 8 6 5

10 8 7 6 4

0 10 20 30 40 50

Node Attribute Browser Edge Attribute Browser Network Attribute Browser Parallel Coordinates

Welcome to Cytoscape 2.4.1 Right-click + drag to ZOOM Middle-click + drag to PAN

Encoding and interaction design decisions

- create custom graph layout
 - guided by biological metadata
- use small multiple views
 - one view per experimental condition
- show measured data in graph context
 - not in isolation

Traditional graph layout

- given graph $G=\{V,E\}$
- create layout in 2D plane
- heavily studied
 - hundreds of papers
 - annual Graph Drawing conf

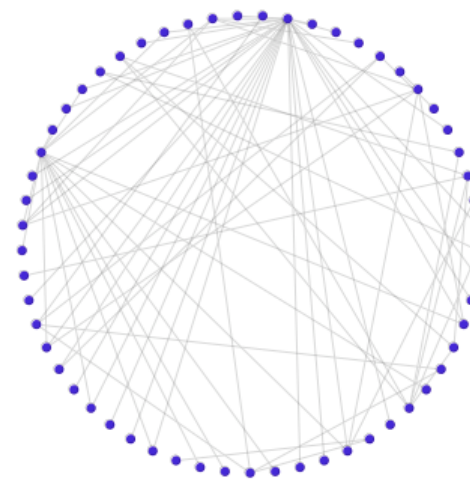

Circular (Six and Tollis, 1999)

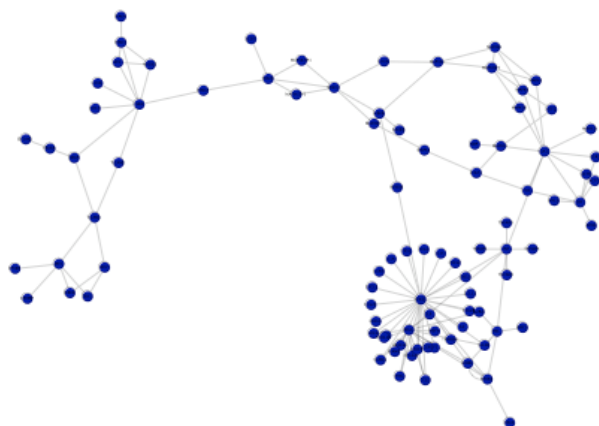

Force-directed
(Fruchterman and Reingold, 1991)

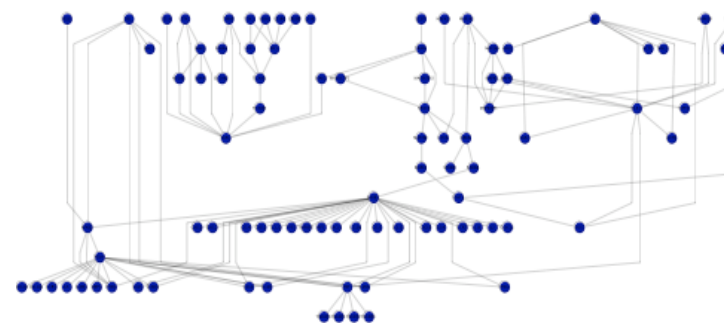

Hierarchical (Sugiyama 1989)

Existing layouts did not suit immunologists

- graph drawing goals
 - visualize graph structure
- biologist goals
 - visualize biological knowledge
 - some relationships happen to form a graph
 - cell location also relevant

Biological cells divided by membranes

- interactions generally occur within a compartment
- crossing membranes is interesting

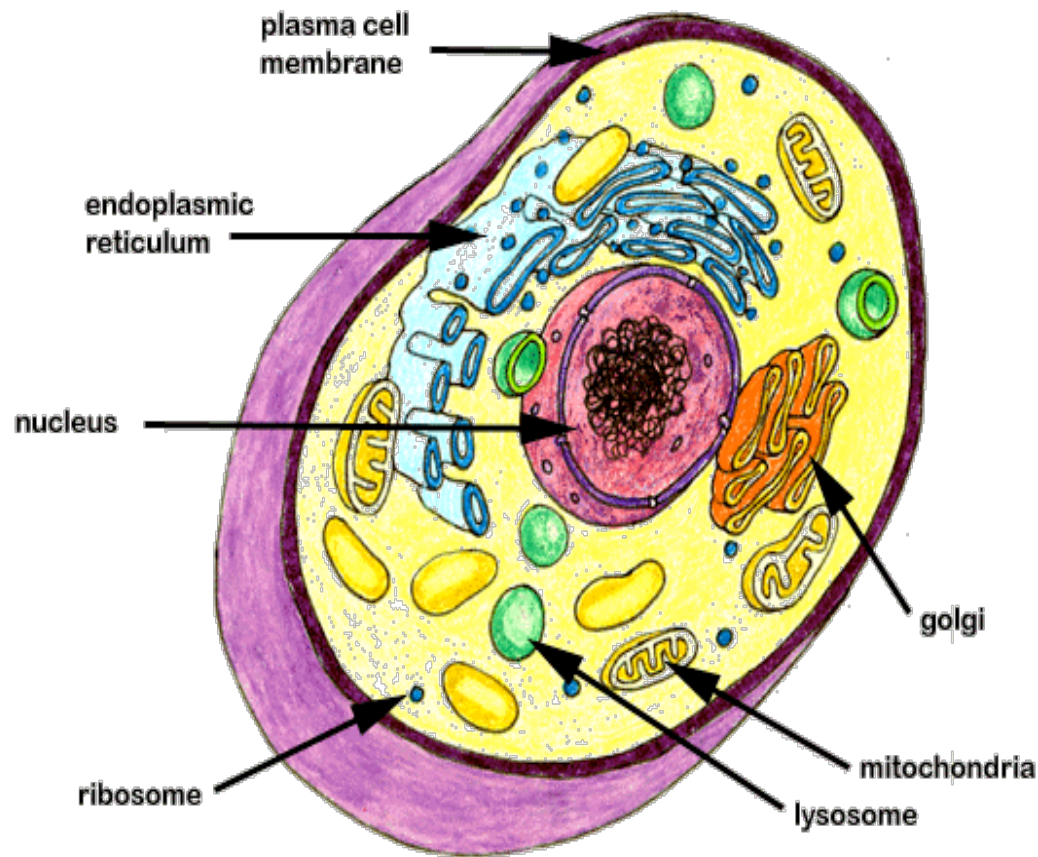
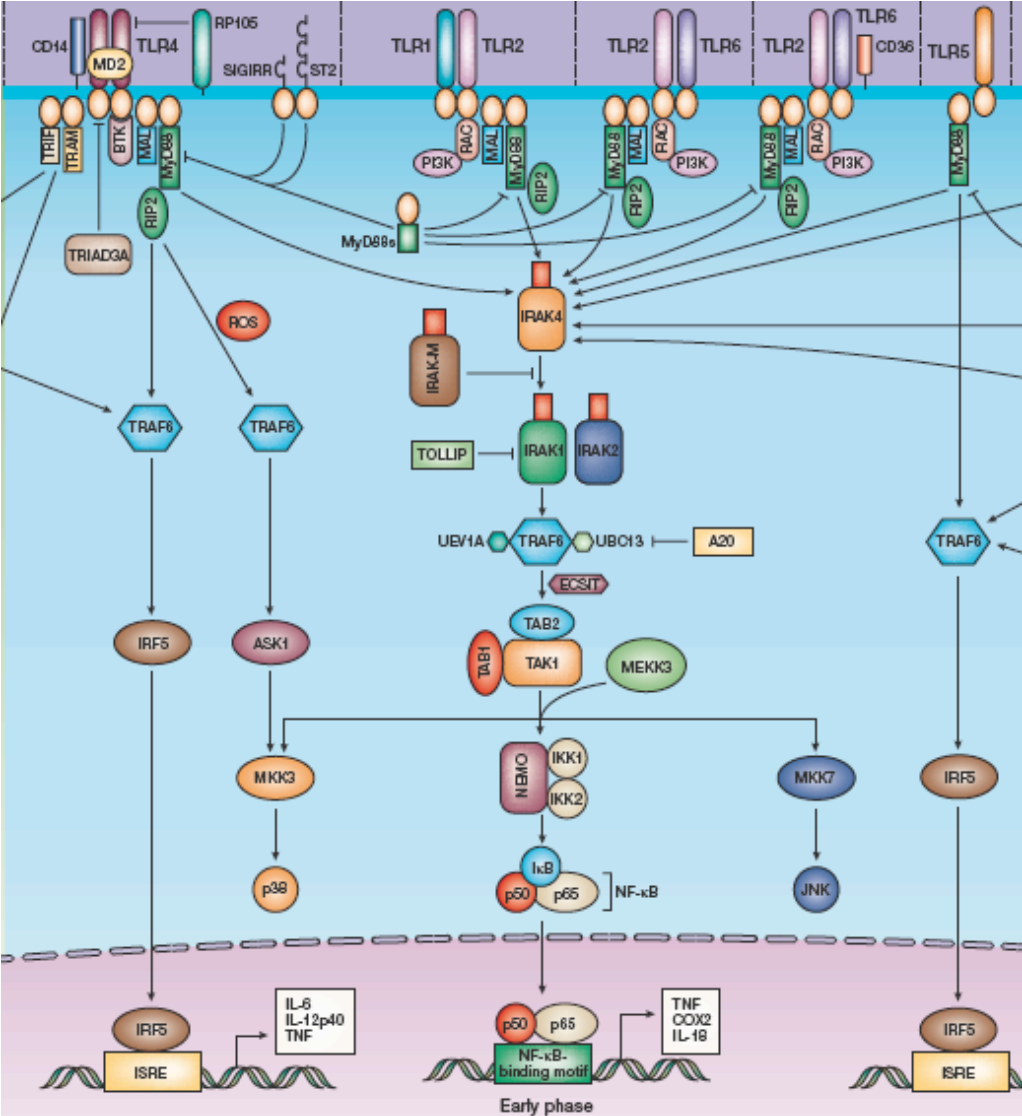

Image credit: Dr.G Weaver, Colorado University at Denver

Hand-drawn diagrams



- cellular location encoded spatially
- infeasible to create by hand in era of big data

<http://www.nature.com/nri/focus/tlr/nri1397.html>

Cerebral layout using biological metadata

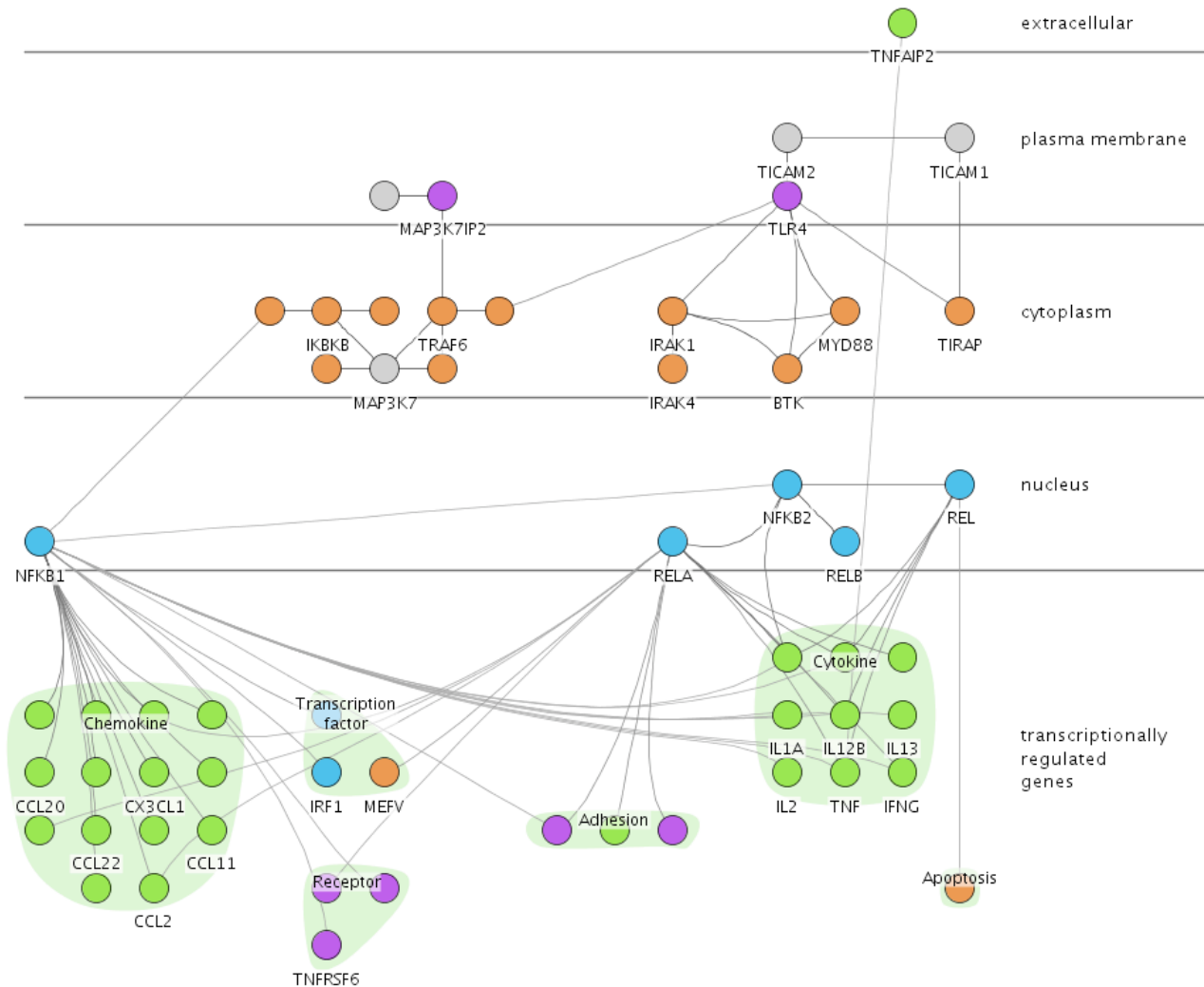

- similar to hand-drawn
- spatial position reveals location in cell
- simulated annealing in $O(E\sqrt{V})$ vs. $O(V^3)$ time

Use small multiple views

- one graph instance per experimental condition
 - same spatial layout
 - color differently, by condition

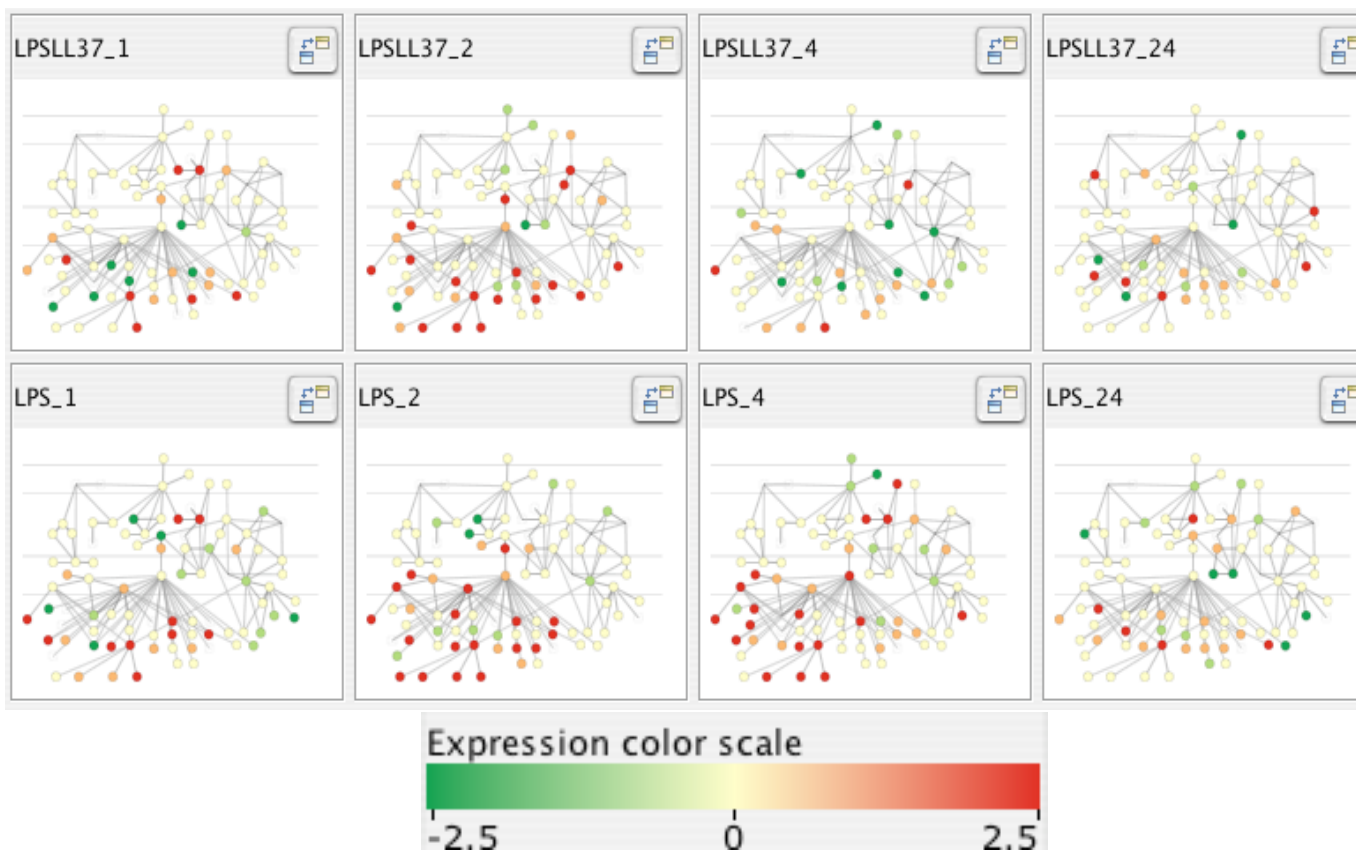

Why not animation?

- global comparison difficult

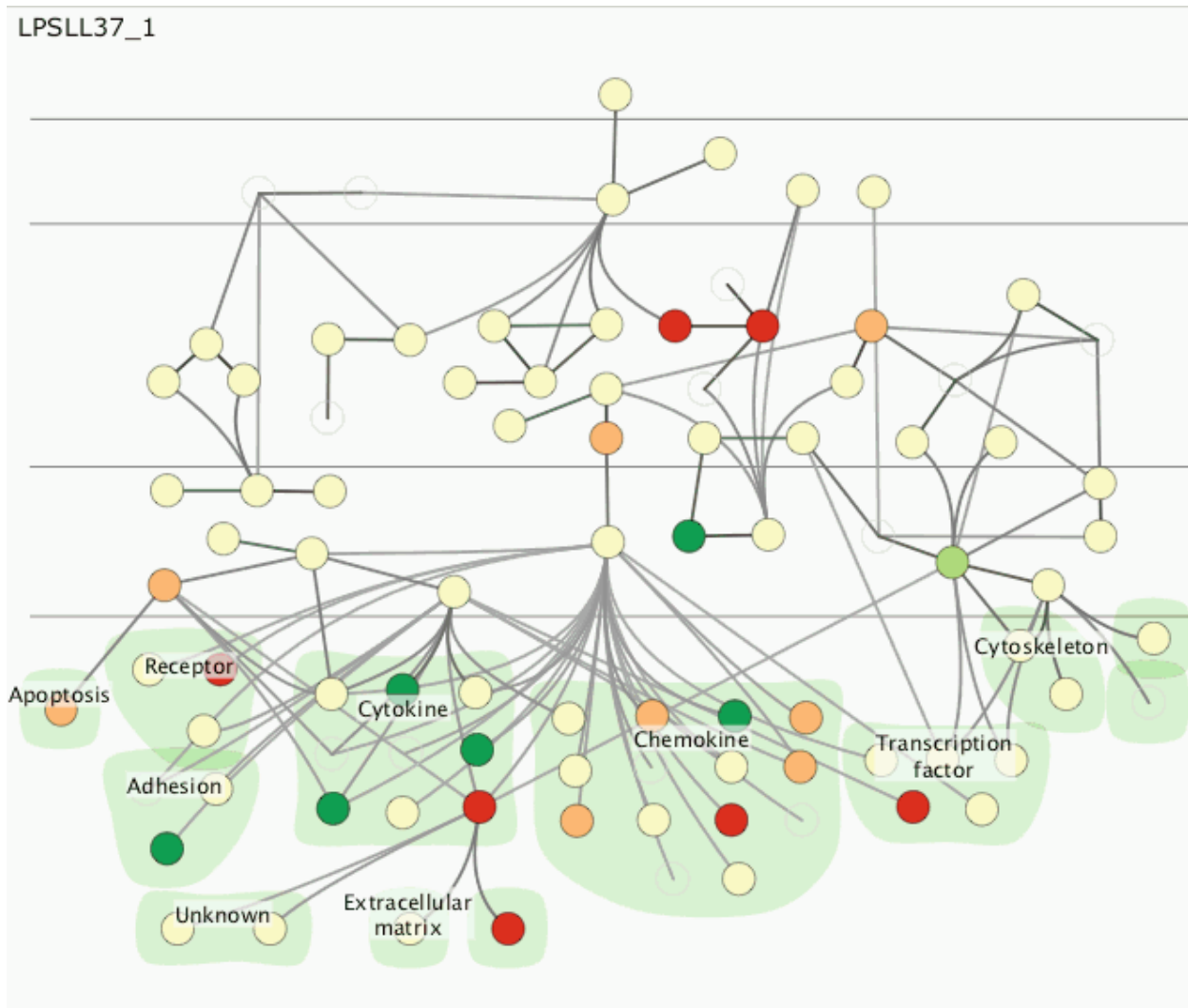

Why not animation?

- limits of human visual memory
 - compared to side by side visual comparison
- Matthew Plumlee and Colin Ware. Zooming versus multiple window interfaces: Cognitive costs of visual comparisons. *ACM Trans. Computer-Human Interaction (ToCHI)*, 13(2):179-209, 2006.
- Barbara Tversky, Julie Bauer Morrison, and Mireille Betrancourt. Animation: can it facilitate? *International Journal of Human-Computer Studies*, 57(4):247-262, 2002.

Why not glyphs?

- embed multiple conditions as a chart inside node
- clearly visible when zoomed in
- but cannot see from global view
 - only one value shown in overview

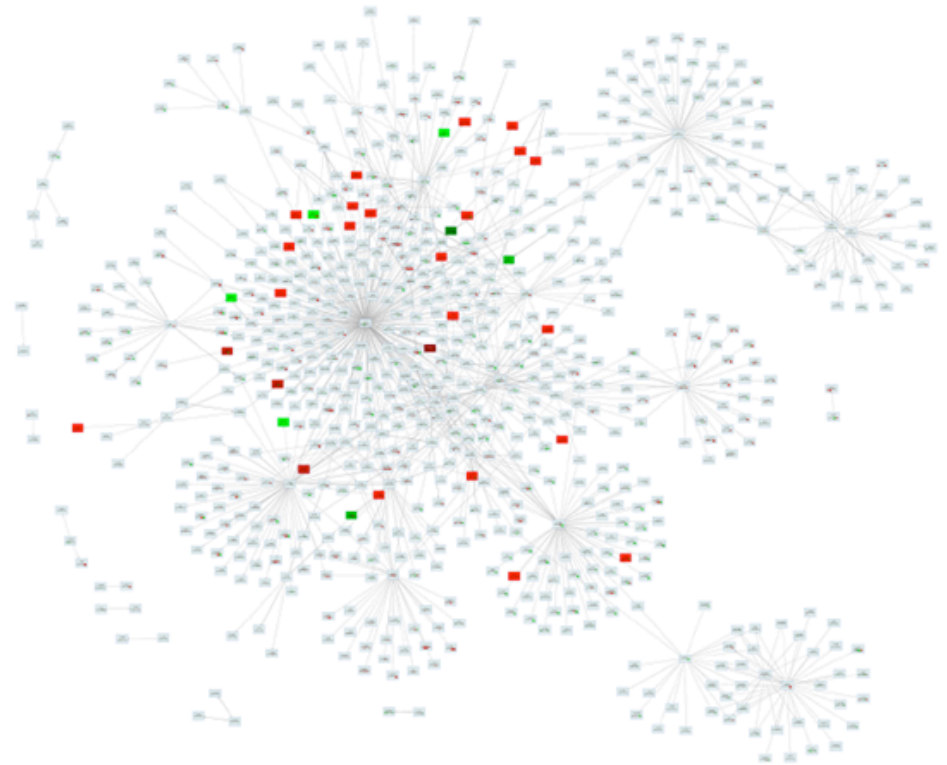
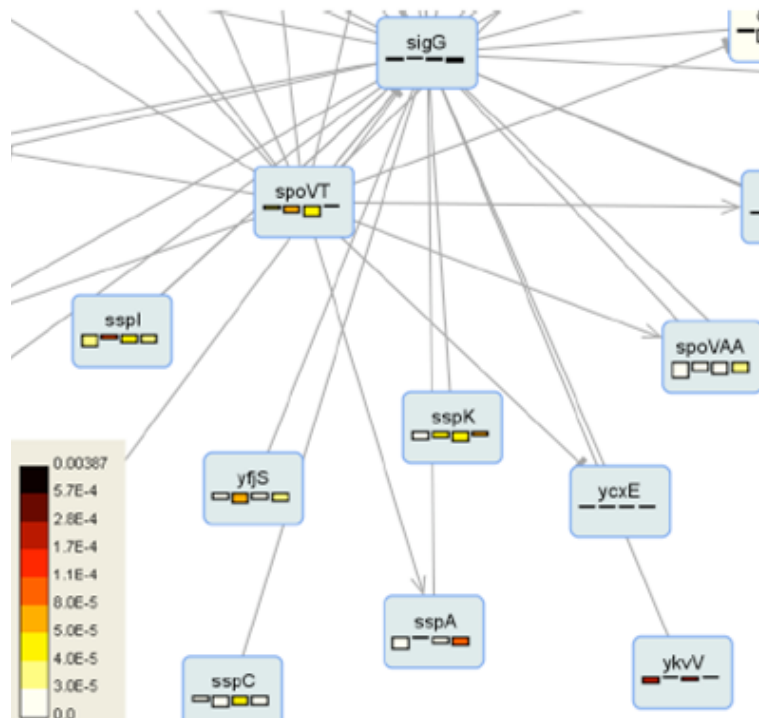

[M. A. Westenberg, S. A. F. T. van Hijum, O. P. Kuipers, J. B. T. M. Roerdink. Visualizing Genome Expression and Regulatory Network Dynamics in Genomic and Metabolic Context. Computer Graphics Forum, 27(3):887-894, 2008.]

Show measured data in graph context

- data driven hypothesis
 - clusters indicate similar function?
 - same pattern of gene expression → same role in cell?
- clusters are often untrustworthy artifacts!
 - noisy data: different clustering alg. → different results
 - measured data alone potentially misleading
 - **show in context of graph model**

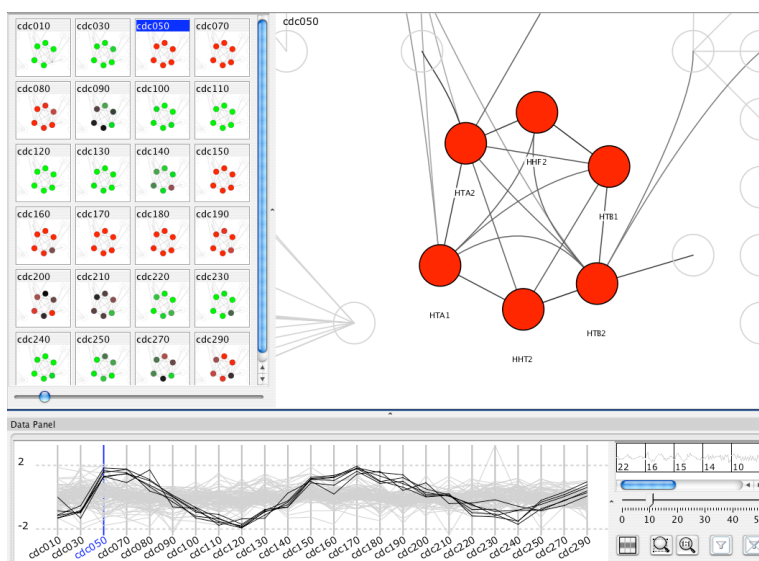

Adoption by biologists

- Matthew D Dyer, T. M Murali, and Bruno W Sobral. The landscape of human proteins interacting with viruses and other pathogens. PLoS Pathogens, 4(2):e32, 2008.

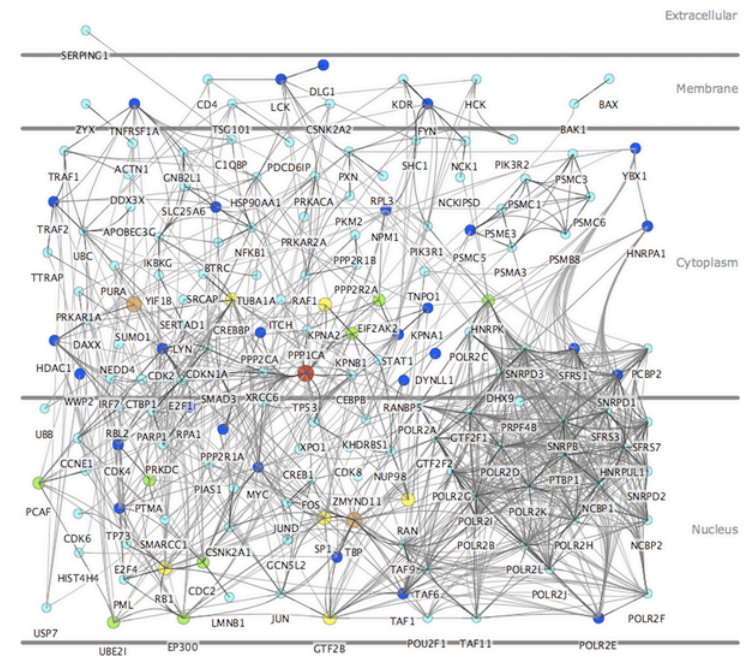

- Liqun He et al. The glomerular transcriptome and a predicted protein-protein interaction network. Journal of the American Society of Nephrology, 19(2):260-268, 2008.

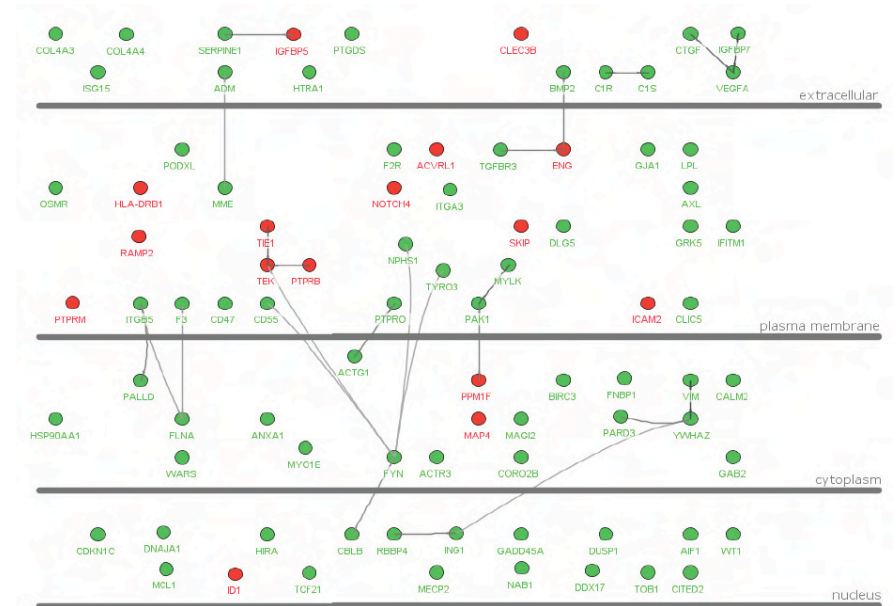

InnateDB links to Cerebral

- InnateDB: facilitating systems-level analyses of the mammalian innate immune response
 - David J Lynn, Geoffrey L Winsor, Calvin Chan, Nicolas Richard, Matthew R Laird, Aaron Barsky, Jennifer L Gardy, Fiona M Roche, Timothy H W Chan, Naisha Shah, Raymond Lo, Misbah Naseer, Jaimmie Que, Melissa Yau, Michael Acab, Dan Tulpan, Matthew D Whiteside, Avinash Chikatamarla, Bernadette Mah, Tamara Munzner, Karsten Hokamp, Robert E W Hancock, Fiona S L Brinkman. *Molecular Systems Biology* 2008; 4:218
 - <http://innatedb.ca>

InnateDB
A Knowledge Resource For Innate Immunity Interactions & Pathways

Home About Search Browse Download Resources Statistics Contact Help

Display Options (Show/Hide)

Sorted by: Interaction Type ascending then by Group ID ascending Sort

Click here to show redundant interactions

Download XML TAB MS Excel CSV SIF **Visualize Cerebral (?)**

Viewing interactions 41 to 60 of 857 hits matching query (Pathway name: 'Human TNF-alpha Signaling Pathway [816]')

Page(s): [Prev] 1 2 3 4 5 6 7 8 9 10 [Next]

Group ID	Interaction	Interactors	Species	Interaction level	Interaction type	Supporting Publications	
40322	CHUK interacts with MAP3K14	CHUK :: MAP3K14	<i>Homo sapiens</i>	direct interaction	phosphorylation	2	Interaction Details
42332	Phosphorylation of NFKBIA by IKBKB	IKBKB :: NFKBIA	<i>Homo sapiens</i>	direct interaction	phosphorylation	3	Interaction Details
42333	Phosphorylation of NFKBIA by CHUK	CHUK :: NFKBIA	<i>Homo sapiens</i>	direct interaction	phosphorylation	3	Interaction Details
42345	IKBKB interacts with NFKBIA	IKBKB :: NFKBIA	<i>Homo sapiens</i>	direct interaction	phosphorylation	11	Interaction Details
42346	CSNK2A1 phosphorylates NFKBIA(IKB alpha)	CSNK2A1P/CSNK2A1 :: NFKBIA	<i>Homo sapiens</i>	direct interaction	phosphorylation	1	Interaction Details
42347	CHUK interacts with NFKBIA	CHUK :: NFKBIA	<i>Homo sapiens</i>	direct interaction	phosphorylation	10	Interaction Details
42348	IKBKG interacts with NFKBIA	IKBKG :: NFKBIA	<i>Homo sapiens</i>	direct interaction	phosphorylation	1	Interaction Details
44310	IKBKE phosphorylates NFKBIA(IKB alpha)	IKBKE :: NFKBIA	<i>Homo sapiens</i>	direct interaction	phosphorylation	1	Interaction Details
44678	IKBKB interacts with IKBKB	IKBKB :: IKBKB	<i>Homo sapiens</i>	direct interaction	phosphorylation	2	Interaction Details
44680	IKBKB (complex)	IKBKB	<i>Homo sapiens</i>	direct interaction	phosphorylation	3	Interaction Details
44681	Phosphorylation of RELA by IKBKB	IKBKB :: RELA	<i>Homo sapiens</i>	direct interaction	phosphorylation	1	Interaction Details
44682	NIK weakly phosphorylates IKK-beta(KA) in vitro	IKBKB :: MAP3K14	<i>Homo sapiens</i>	direct interaction	phosphorylation	1	Interaction Details

Data cleansing example

- incorrect edge across many compartments
 - in well studied dataset
 - not obvious with other layouts

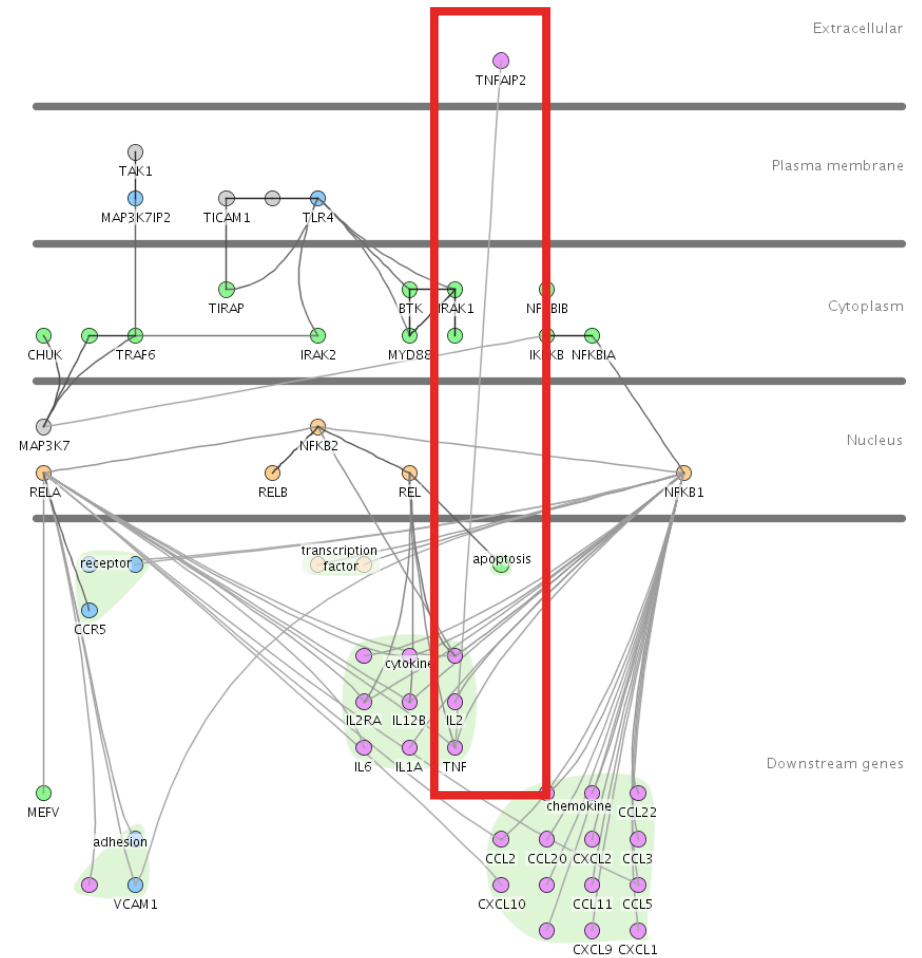
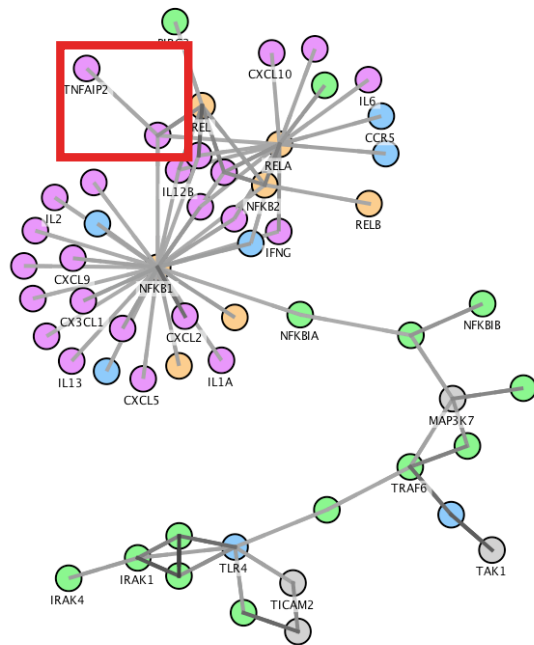

Cerebral summary

- supports interactive exploration of multiple experimental conditions in graph context
- provides familiar representation by using biological metadata to guide graph layout

Outline

- visualization ideas and background
- combining interaction networks, microarray data
 - Cerebral system
- comparing phylogenetic trees
 - TreeJuxtaposer system
- discussion

TreeJuxtaposer

collaboration with biologists at UT-Austin Hillis Lab

TreeJuxtaposer: Scalable Tree Comparison using Focus+Context with Guaranteed Visibility.

Tamara Munzner, François Guimbretière, Serdar Tasiran, Li Zhang, Yunhong Zhou.
ACM Trans. Graphics 22(3): 453-462, 2003 (Proc. SIGGRAPH 2003).

<http://www.cs.ubc.ca/labs/imager/tr/2003/tj>

open-source software download

<http://olduvai.sourceforge.net/tj>

Phylogenetic (evolutionary) tree

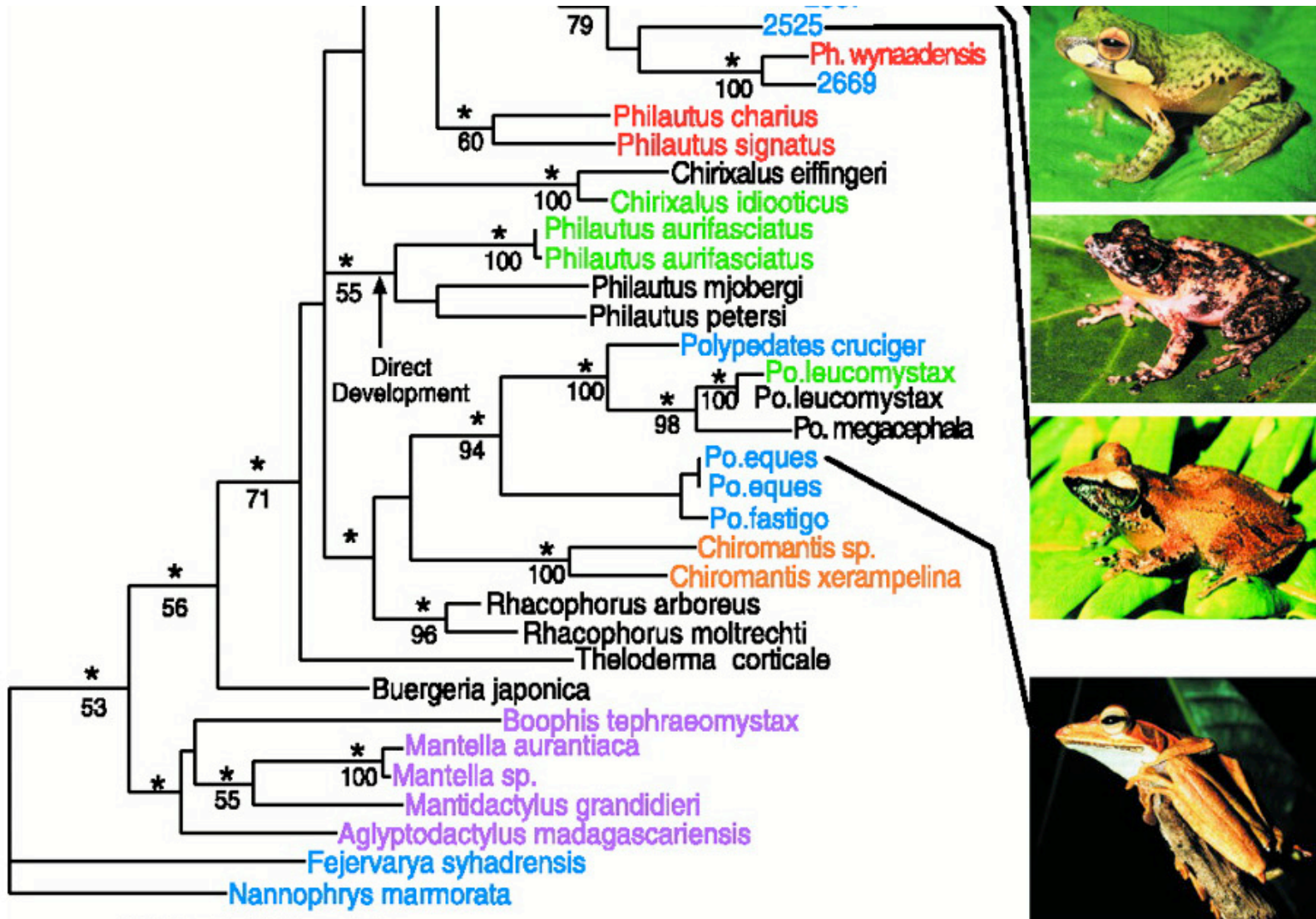

M Meegaskumbura et al., Science 298:379 (2002)

Common dataset size today

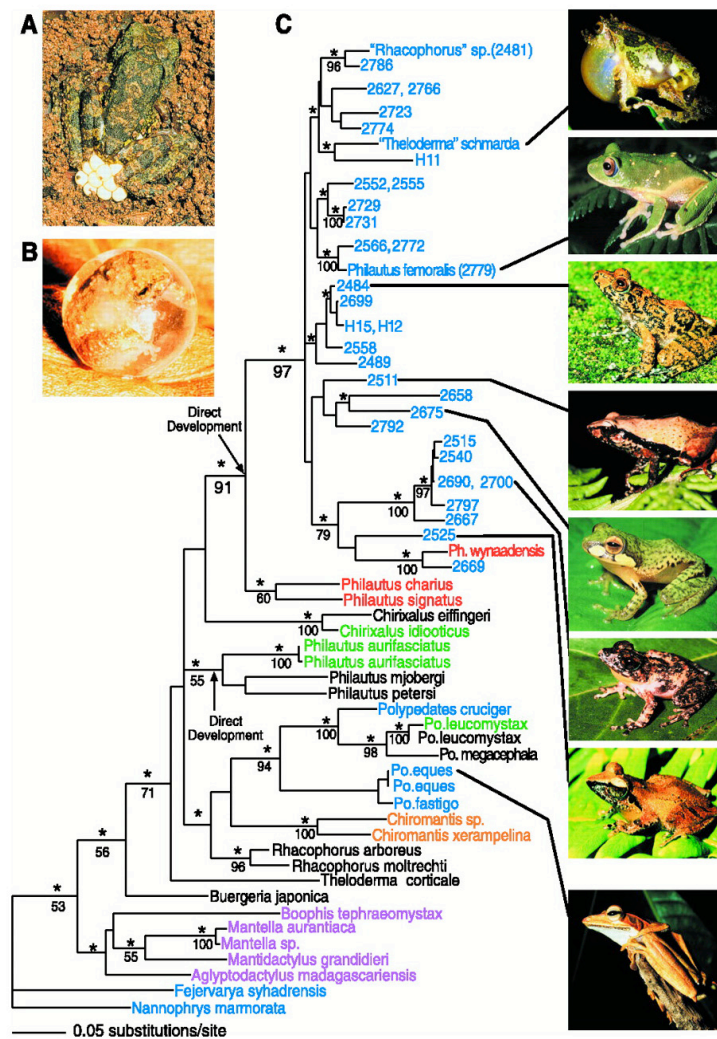

M Meegaskumbura et al., Science 298:379 (2002)

Future goal: Full Tree of Life, ~10M nodes

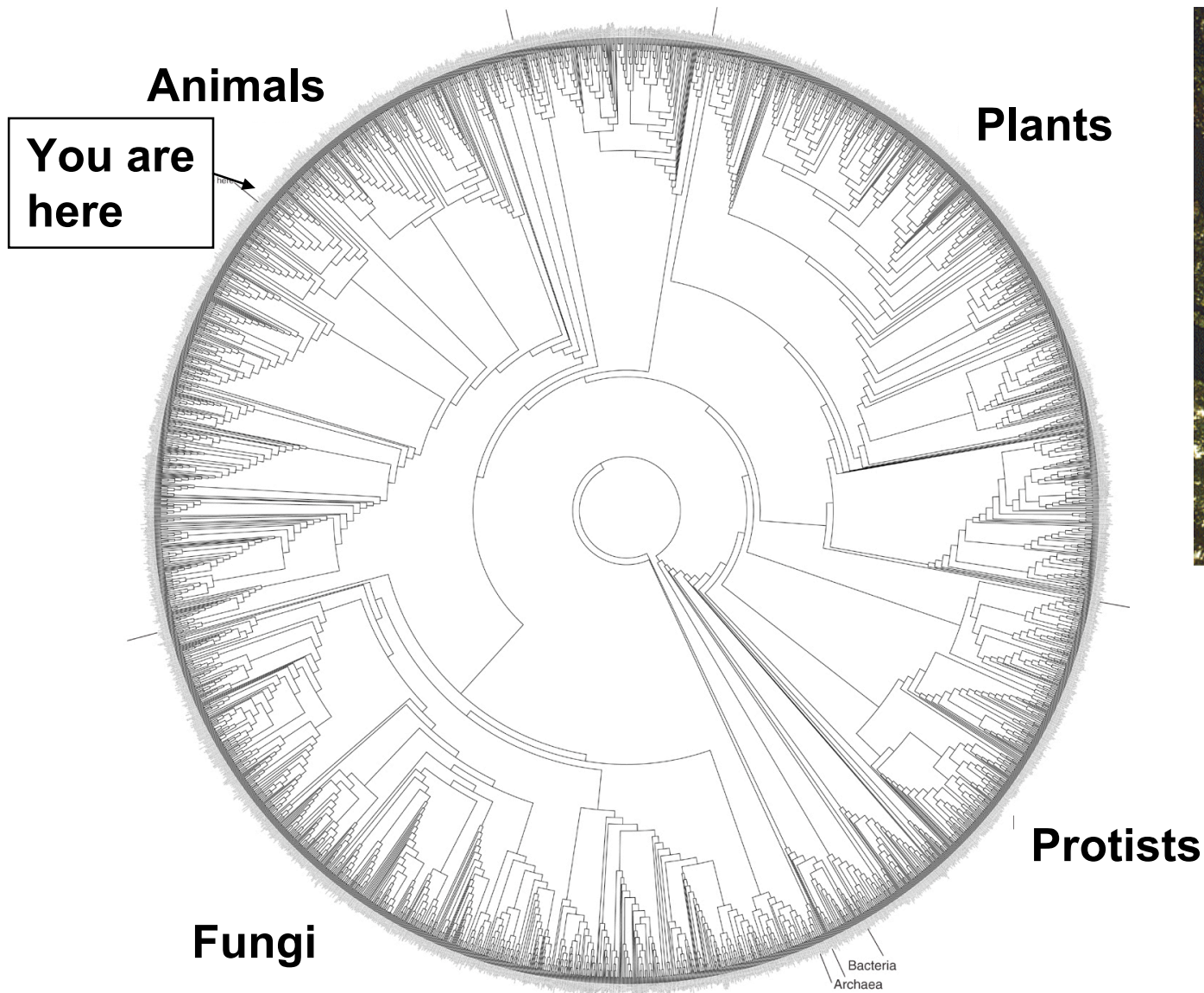

David Hillis, *Science* 300:1687 (2003)

Operation: Comparing multiple trees

- presentation: single tree shown as final result
- exploration: determine true tree from many possibilities
 - different biological conjectures or data
 - different phylogenetic reconstruction algorithms
 - multiple alternatives from same reconstruction algorithm
- most previous work on browsing
 - necessary but not sufficient for comparison

Limitations of paper: Scale and speed

- literal: actual paper
- figurative: interfaces with same semantics as paper

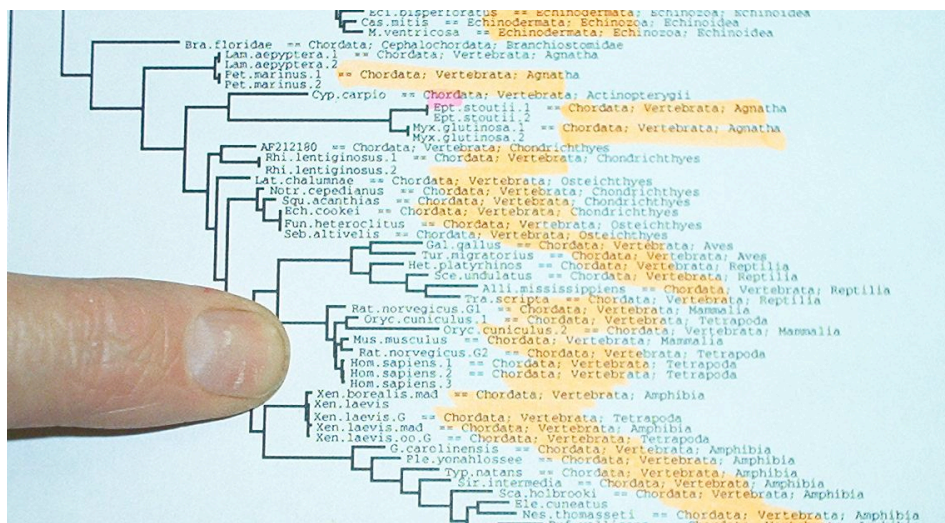

need to focus on details

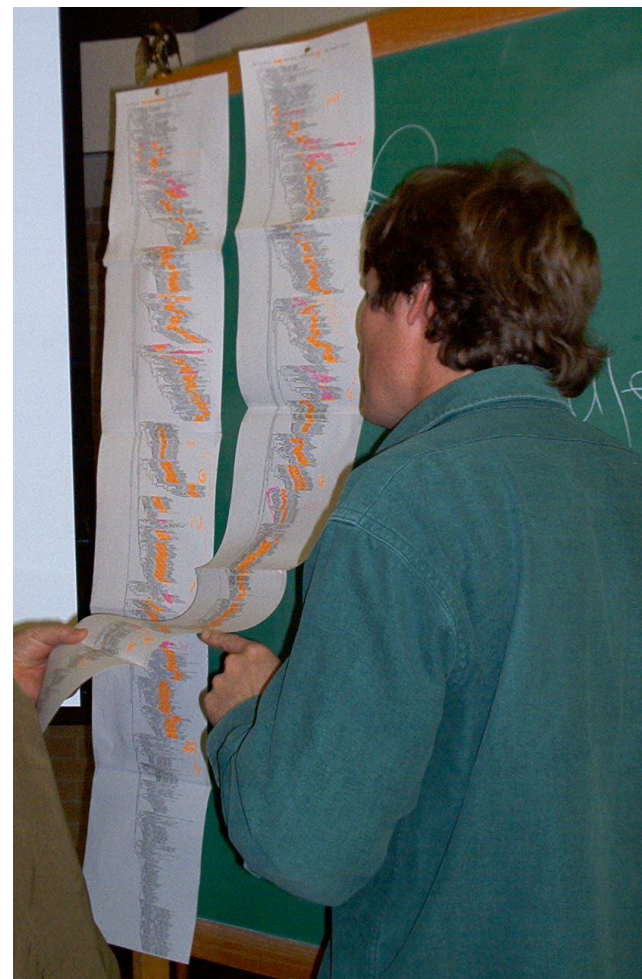

yet maintain context

TreeJuxtaposer video

- stretch and squish navigation
- linked side by side comparison

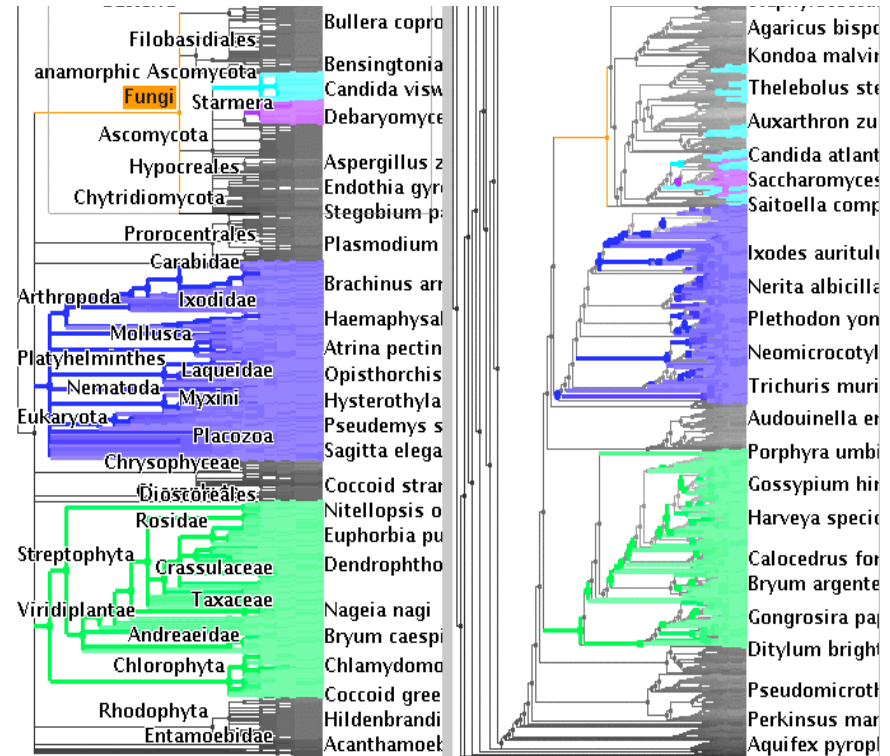
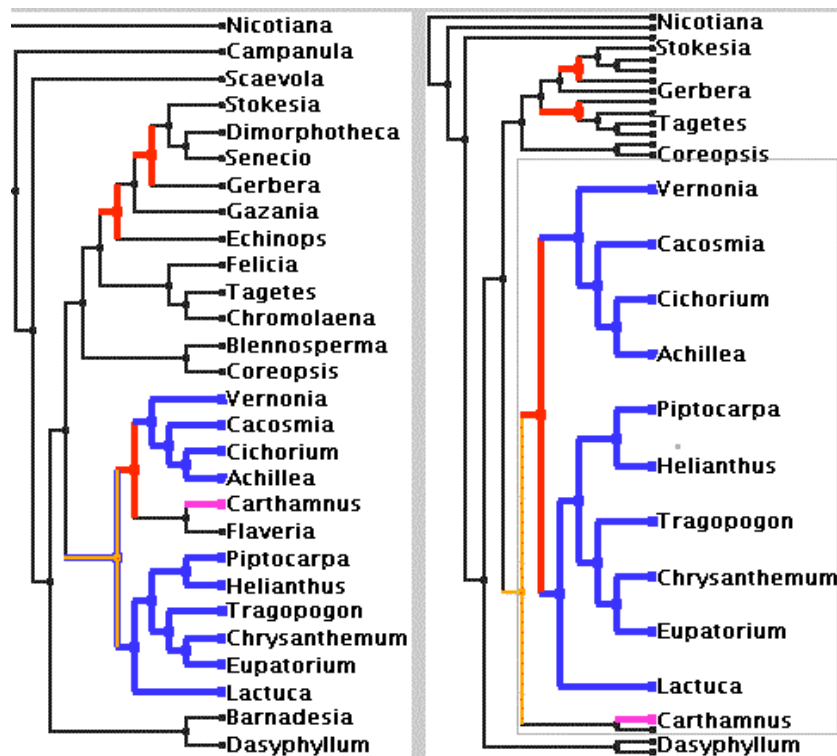

Encoding and interaction design decisions

- linking tree views through node correspondences
 - showing structural differences
- guaranteed visibility of small marks
 - scaling up to millions of nodes

Showing differences via contiguous groups

- clade: ancestor + all descendants
- biological questions to support
 - is a clade in one tree also a clade in other?
 - is some group a clade?

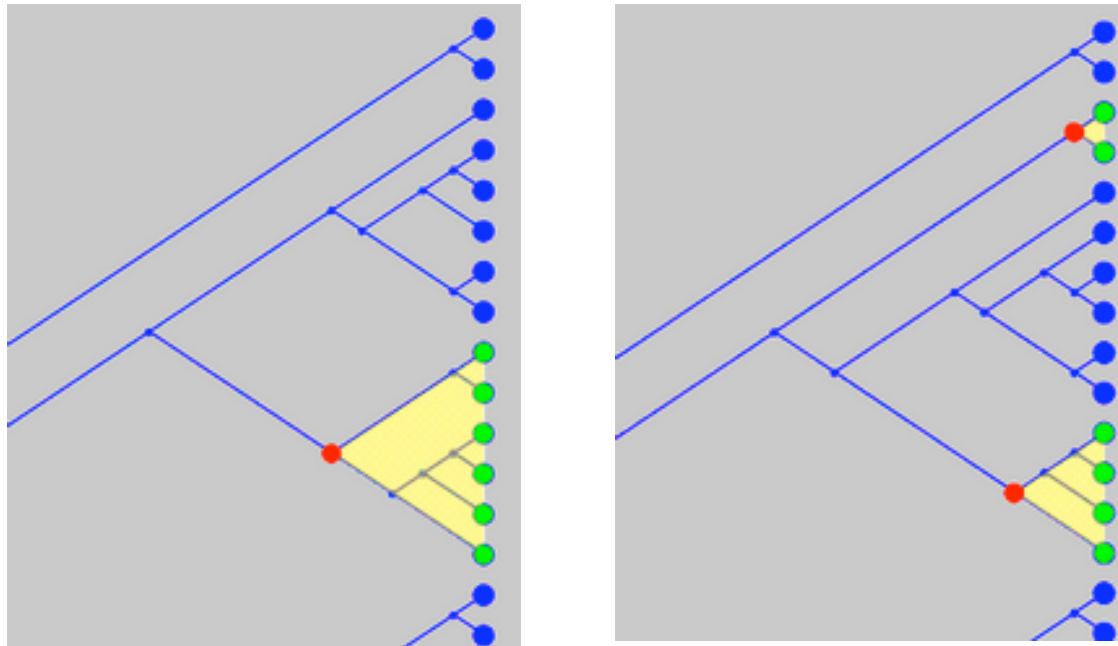

Best corresponding node between trees

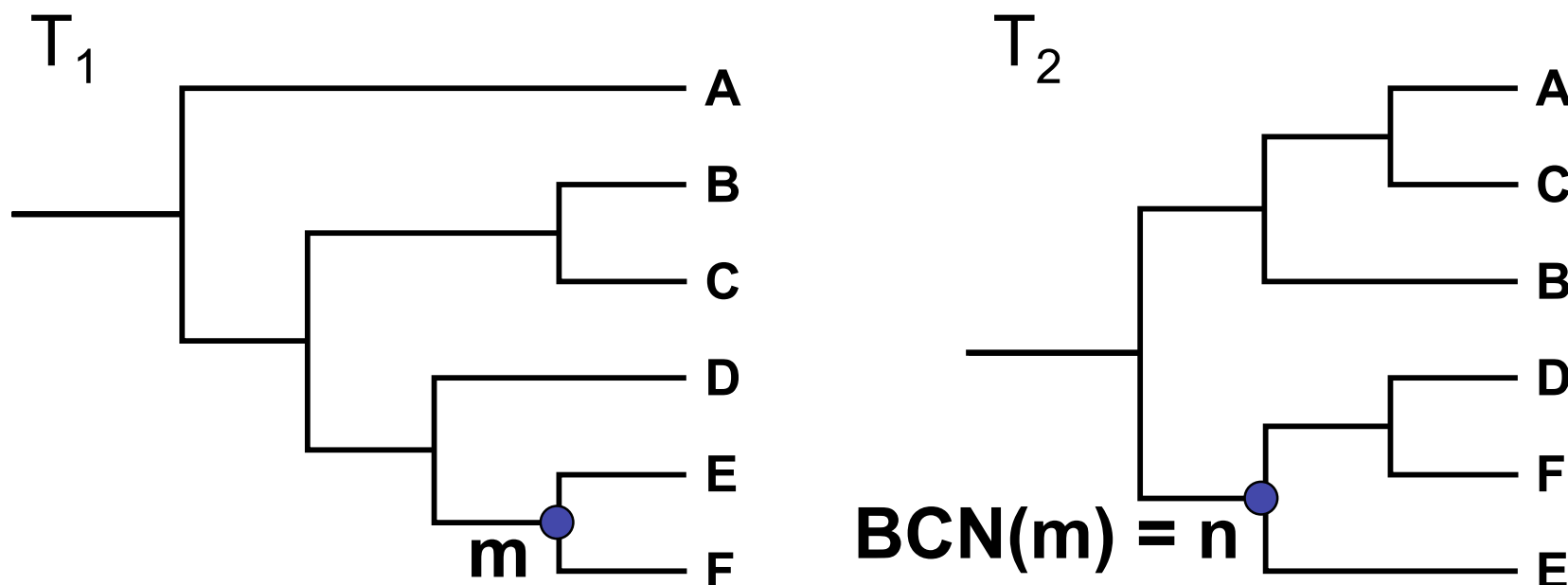

- used for
 - comparing clades between trees
 - linked highlighting on mouseover
 - structural difference highlighting
- algorithm scalability challenge
 - computable in $O(n \log^2 n)$, vs. naive $O(n^2)$

Guaranteed visibility

- marks are always visible
 - structural differences, search results, user selections
- easy with small datasets
 - regions of interest shown with color highlights

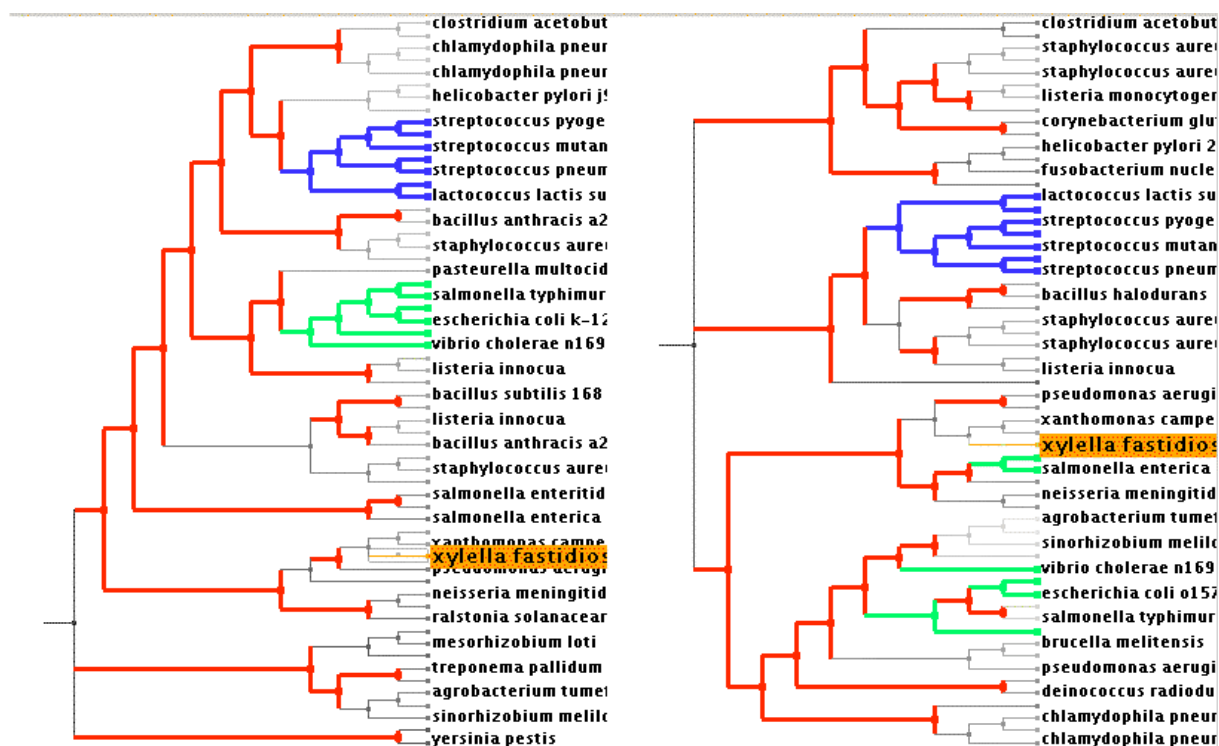

Guaranteed visibility challenges

- hard with larger datasets
- reasons a mark could be invisible

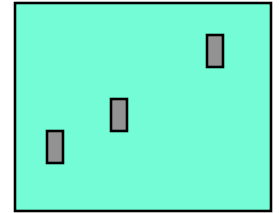

Guaranteed visibility challenges

- hard with larger datasets
- reasons a mark could be invisible
 - mark outside the window
 - solution: constrained navigation

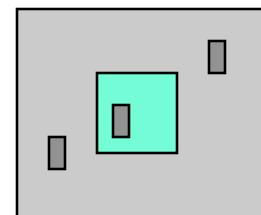
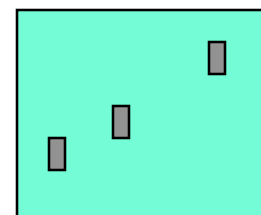

Constrained navigation for visibility

- stretch and squish navigation
 - stretch out part of surface, the rest squishes
 - borders nailed down
 - integrated focus and context
- items never fall outside camera
 - but squished regions can have many items per pixel

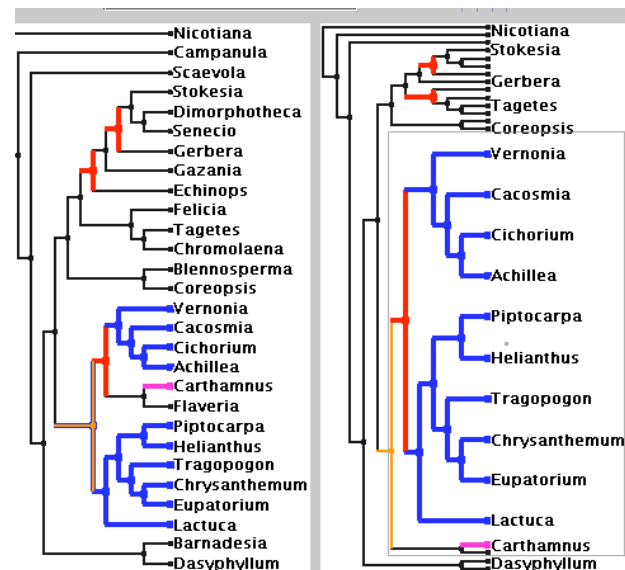

Guaranteed visibility challenges

- hard with larger datasets
- reasons a mark could be invisible
 - mark outside the window
 - solution: constrained navigation
 - mark underneath other marks
 - solution: use 2D not 3D layout

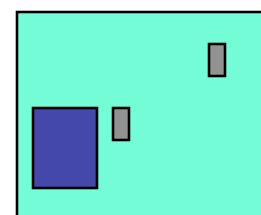
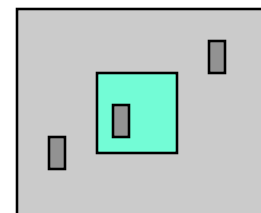
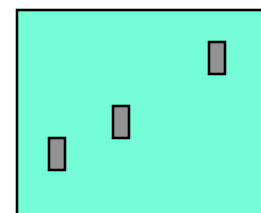

Guaranteed visibility challenges

- hard with larger datasets
- reasons a mark could be invisible
 - mark outside the window
 - solution: constrained navigation
 - mark underneath other marks
 - solution: use 2D not 3D layout
 - mark smaller than a pixel
 - solution: smart culling

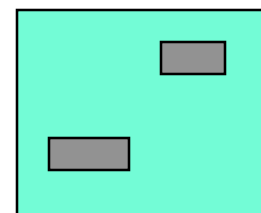
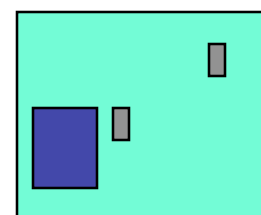
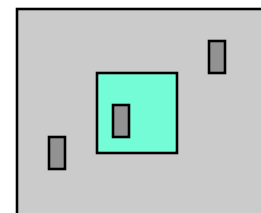
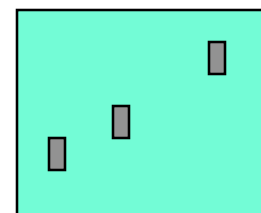

Smart culling for small item visibility

- naïve culling does not draw all marked items
 - graphics cards optimized for realism: small items far away and thus not important
 - rendering infrastructure for visualization semantics: small items might be critical!

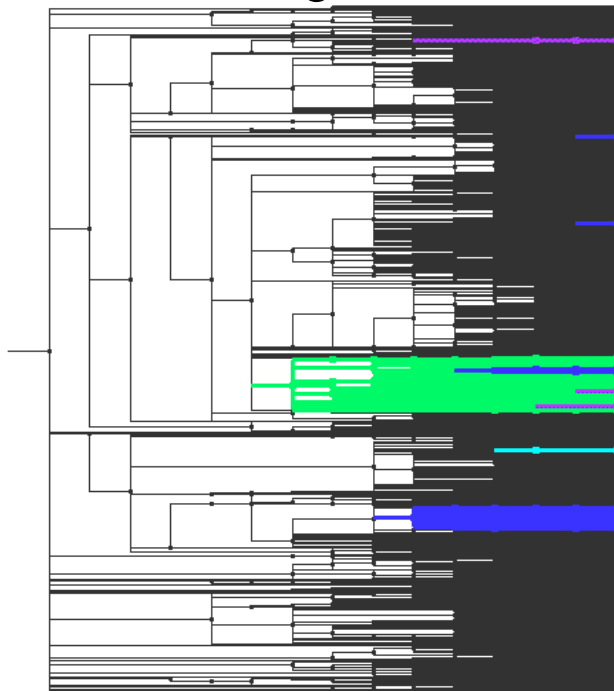

guaranteed mark visibility

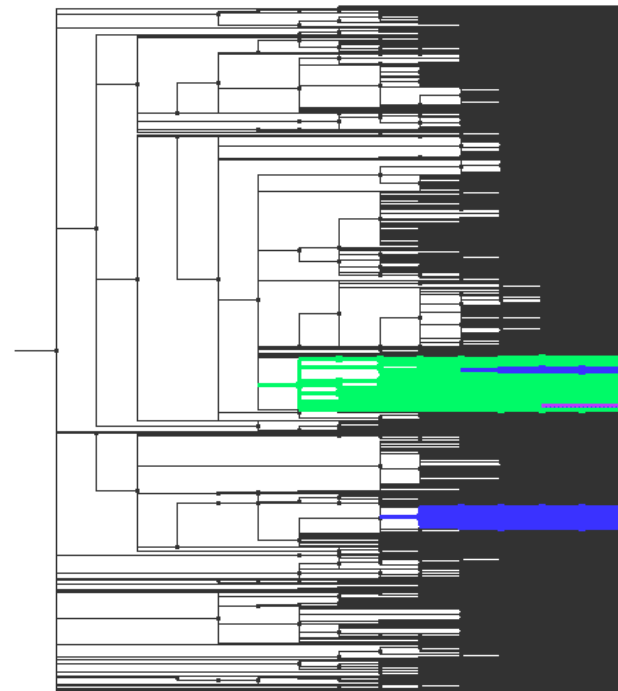

no guaranteed visibility

Guaranteed visibility benefits

- with GV
 - no mark is visible means no need to explore area further
- without GV
 - risk of false negative conclusions, or
 - user must do tedious exhaustive search to ensure nothing missed
- algorithm scalability challenge
 - rendering complexity based on number of onscreen pixels
 - not total number of items in dataset
 - Partitioned Rendering Infrastructure for Scalable Accordion Drawing (Extended Version). James Slack, Kristian Hildebrand, and Tamara Munzner. *Information Visualization*, 5(2), p. 137-151, 2006
 - Composite Rectilinear Deformation for Stretch and Squish Navigation. James Slack and Tamara Munzner. *Proc. Visualization 2006*, published as *Transactions on Visualization and Computer Graphics* 12(5), September 2006.

TJ summary

- first interactive tree comparison system
 - automatic structural difference computation
 - guaranteed visibility of small marks
- scalable to large datasets
 - 250K to 500K total nodes: original
 - up to 4M nodes: later, with PRISAD
 - subquadratic preprocessing
 - sublinear realtime rendering
 - depends on number of pixels, not number of nodes

Outline

- visualization ideas and background
- combining interaction networks, microarray data
 - Cerebral system
- comparing phylogenetic trees
 - TreeJuxtaposer system
- discussion

Many other bio/vis research areas

- multiple sequence alignment
 - SequenceJuxtaposer

open-source software download

<http://olduvai.sourceforge.net/sj>

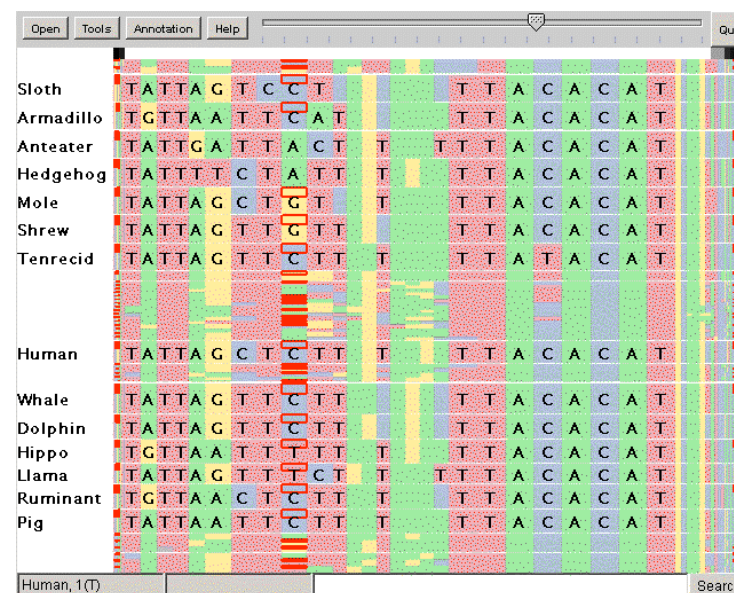

SequenceJuxtaposer: Fluid Navigation For Large-Scale Sequence Comparison In Context. James Slack, Kristian Hildebrand, Tamara Munzner, and Katherine St. John. German Conference on Bioinformatics 2004, pp 37-42

<http://www.cs.ubc.ca/labs/imager/tr/2004/sj/>

Many other bio/vis research areas

- microarray data
 - Hierarchical Clustering Explorer
<http://www.cs.umd.edu/hcil/hce/>
Seo and Shneiderman, U Maryland

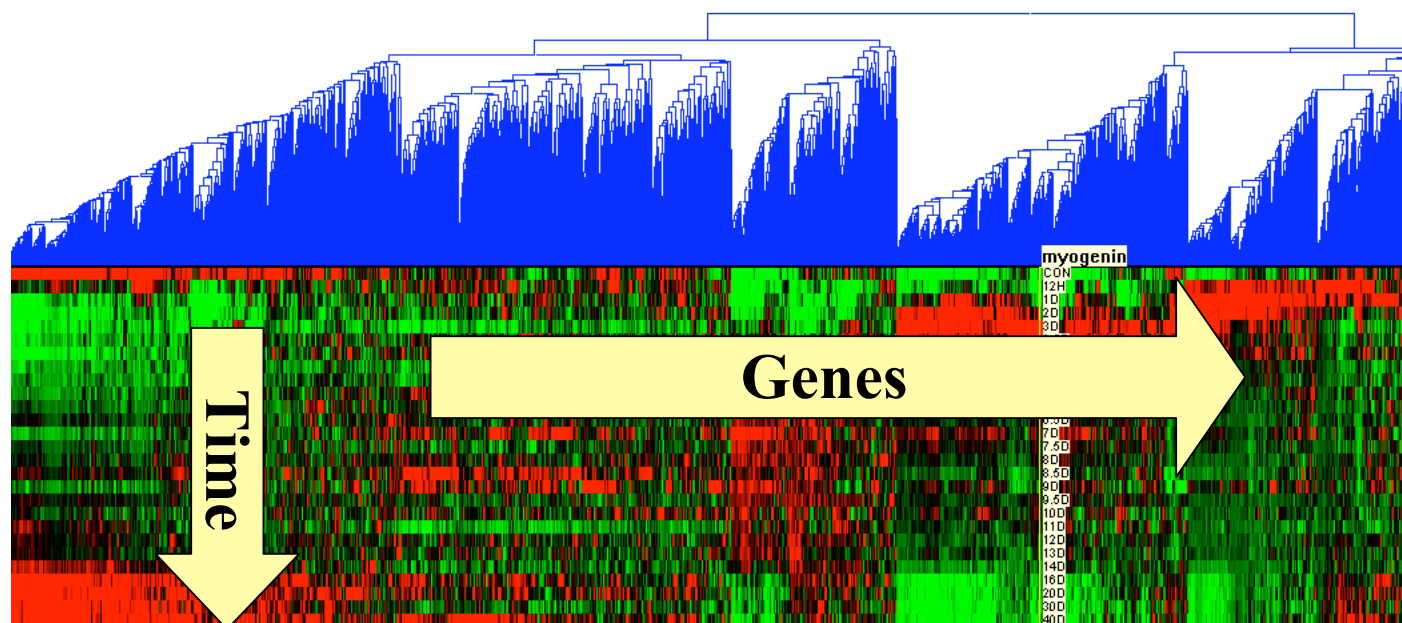

Many more, bio/health + others...

- NIH/NSF Visualization Research Challenges Report
Johnson, Moorhead, Munzner, Pfister, Rheingans, and Yoo
(eds.), IEEE Press
http://vgtc.org/wpmu/techcom/?page_id=11

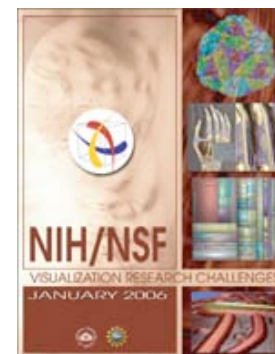
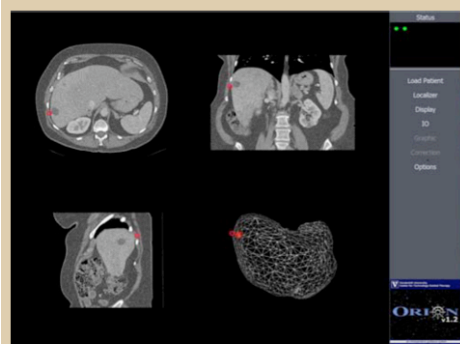
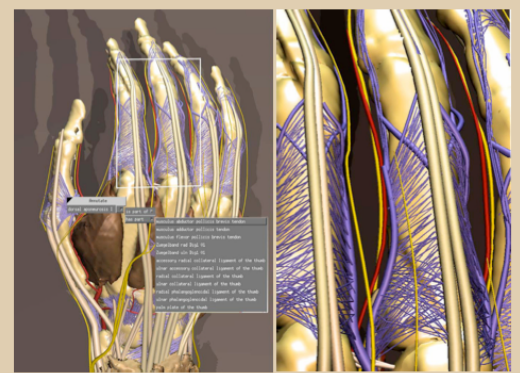

Image Guided Surgery



Teaching Anatomy and Surgery



Visualization of Genomes

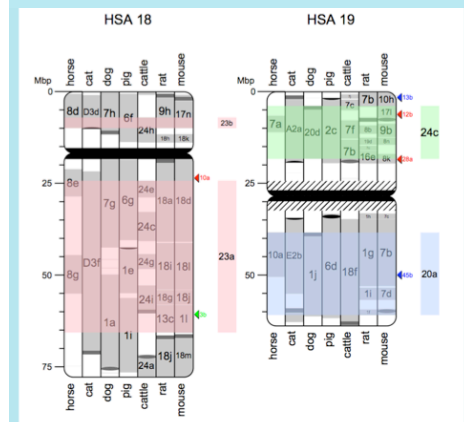

Virtual Colonoscopy

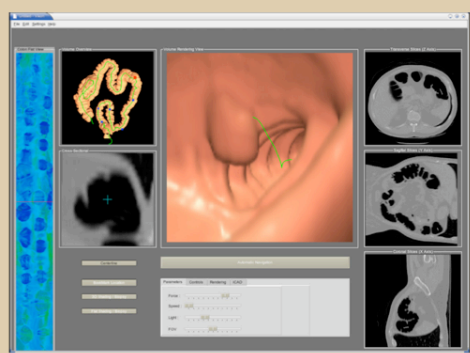

Virus Structure

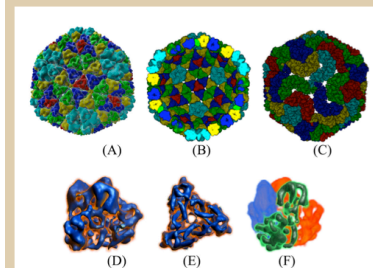

Health Demographics

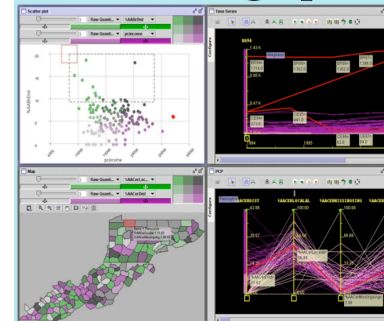

Crosscutting themes

- workflow speedups
 - inspecting microarray data with graph
 - minutes vs. hours/days
 - comparing clades between trees
 - seconds vs. hours/days
- contributions from biologist collaborators
 - driving problems and data
 - tool use during iterative refinement

Vast opportunities

- young field, still much to be done
- think about your current workflow
 - what could you speed up by swapping in perception for cognition?
 - exploit the familiar, yet consider breadth of design alternatives
- finding some friendly neighborhood vis collaborators
 - IEEE VisWeek 2009 (Vis, InfoVis, VAST)
Oct 11-16, Atlantic City
<http://vis.computer.org/VisWeek2009>
 - EuroVis 2009: Jun 10-12, Berlin
<http://www.zib.de/eurovis09>

More information

- this talk

<http://www.cs.ubc.ca/~tmm/talks.html#harvard09>

- papers, videos

<http://www.cs.ubc.ca/~tmm>

- software

<http://olduvai.sourceforge.net/tj>

<http://www.pathogenomics.ca/cerebral>

<http://www.innatedb.ca>